



TRANE®

Multipipe Chiller RTMA

Air/water units for associated systems
with four pipes

-  Up to Class A
-  Screw compressors
-  Axial fans
-  Finned coil
-  Outdoor installation
-  Refrigerant R134a



Cooling capacity: from 369 kW up to 733 kW, heating capacity: from 412 kW up to 812 kW.

Index

1. **Product presentation**
2. **Operating modes**
3. **Unit designation**
4. **Technical specification**
5. **Accessories on demand**
6. **Energy Efficiency ratios**
7. **Technical data**
8. **Operating range**
9. **Scaling correction schedules**
10. **Hydraulic data**
11. **Electrical data**
12. **Acoustic data**
13. **Installation sketch**
14. **Dimensional drawings and weights**

1. PRODUCT PRESENTATION

4PIPE SYSTEM



The units belonging to the **RTMA** range are high efficiency multifunctional units for 4-pipe systems with axial fans and scroll compressors.

The possible installation are several, but generally they are the ideal solution for all those buildings undergoing strong opposite variable loads during the whole year.

The main applications are therefore:

- Buildings with a double and opposite sun exposure.
- Airports
- Hotels
- Banks
- Discos, in which cooling for the dance floor zone and heating for those areas dedicated to conversation are simultaneously needed.
- Wellness centers where areas with opposite loads requirements are present;
- Datacenter, where the server zone needs to be cooled while the office area needs to both heating and cooling;
- Hospital, in particular the operating theatre where the cooling or heating demand is independent from the season;

The four-pipe technology is considered the best energy efficient solution able to satisfy the complex needing of all those buildings where it is necessary to neutralize simultaneous opposite thermal loads.

RTMA, operating in total heat recovery mode, is able to satisfy the simultaneous demand of hot and cold water all over the year, simplifying the plant and reducing operating costs.



Shopping malls

Hospitals

Airports

Hotels

Wellness center

MICROPROCESSOR DRIVEN ELECTRONIC EXPANSION VALVE



The use of the electronic expansion valve allows to:

- Maximize the the heat Exchange at the evaporator;
- Minimize the response time according to the load variation;
- Optimize the superheating regulation and ensure the maximum energy efficiency.

HIGH PERFORMANCE TEMPERATURE HPT (OPTIONAL)



It allows to reach hot water temperature up to 65°C in order to satisfy particular hot water needs or also to program anti-legionella sanitification cycles.

REFRIGERANT CIRCUIT

The refrigerant circuit is optimized to allow avoiding fault of the unit caused by anti-freeze alarms. These alarms happens frequently for all the standard multi-functional units not equipped with the appropriate circuit design. The reliability of the system considerably increases the working reliability of the unit.

50 % LESS DEFROST CYCLES

A innovative technology has been implemented in the electronic control system in order to significantly decrease the number of defrosting cycles, reducing drastically the production of negative energy towards the plant, where a heat pump normally uses to switch the cycle in chiller mode producing cold water.

It is a digital self-adaptive defrosting system able to intervene only in case of a consistent thickness formation of ice on the coils' fins. In particular, the system reduces the number of defrosting cycles by monitoring the outdoor conditions and the unit evaporation and activates the defrost function only if necessary and if the coils are really iced. Thanks to this technology the number of defrosting cycles decreases by 50%.

The reduction of mechanical stress, due to the cycle inversions during heating mode, implies an increase in the life cycle of the unit, as well as improving the comfort felt by the user.

DYNAMIC LOGIC CONTROL

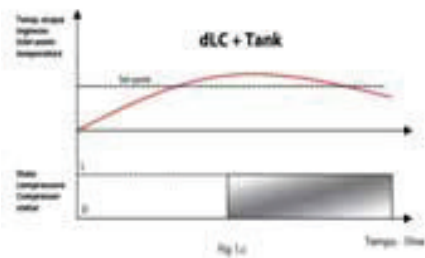
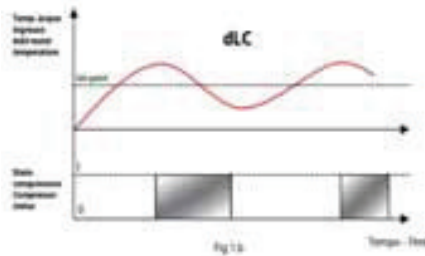
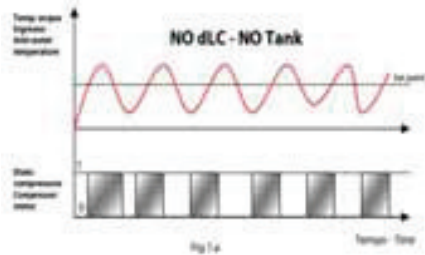

The electronic controller can manage the differential of the inlet water temperature on the basis of the speed of its variation. The function dLC works partially as a simulator of a water tank: in fact it allows to reduce the number of the compressor's starts. The main advantage of the function dLC is during the conditions of low load, that is:

- the compressor is switched off and the water temperature increases very slowly; in this situation the dLC is able to delay the start of the compressor by replacing itself to the thermal inertia that would be obtained from the water tank;
- the compressor is switched on and the water temperature decreases very quickly; in this situation the dLC is able to delay the compressor's switching off. In this way it is reached the same result that would be obtained from the water tank's thermal inertia.

As result the function dLC makes possible to reduce the dimensions of the water tank, with huge advantages for the footprint of the unit .

Figure 1 shows how the compressor's startups decrease by passing from a system with no tank and without dLC (1.a) to a system with dLC (1.b) and to a system with dLC and a small water tank (1.c). It can be seen that this last solution is still the best, though the tank dimensions can be reduced.

DYNAMIC SET POINT

During the heating season the outdoor temperature changes from the design temperature, and consequently the heating load of the plant changes too. It is therefore possible to adjust the outlet water temperature according to outdoor temperature by the use of a set point regulation following a climatic curve.

MULTIPIPE CHILLER RTMA

With a bivalent outdoor temperature of -7°C with fan coils distribution (working with an inlet water temperature of 45°C) it is possible to adjust the outlet water temperature as per a linear trend between the bivalent temperature and 15°C (temperature value to which the heating load is assumed to be zero). The curve shown is an example of possible regulation: the **DYNAMIC SET POINT** allows to set a regulation curve according to the design choices and to the requirements of each installation. This control allows to keep a high level of comfort and highlights the efficiency of the heat pump.

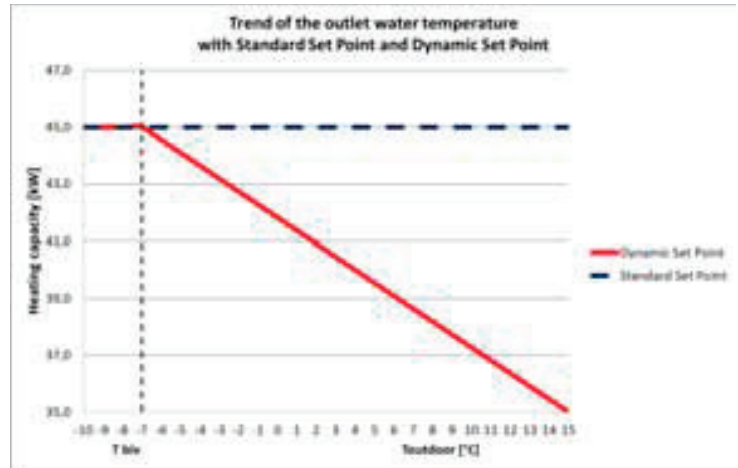

The efficiency in fact increases with the decrease of the outlet water temperature thanks to a lowest condensing temperature of the refrigerant. The diagram shows the COP trend for the standard set point and the Dynamic Set Point. The **DYNAMIC SETPOINT** allows to adjust the working set point of the unit maximizing the comfort and the efficiency of the unit.

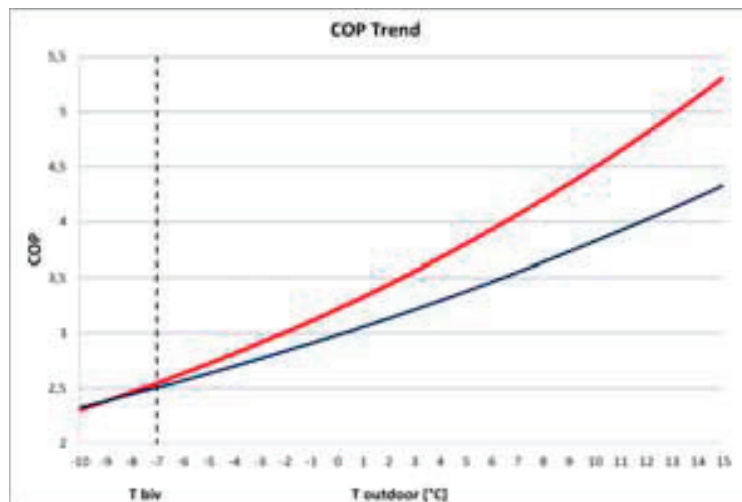

ELECTRONICALLY COMMUTATED BRUSHLESS FANS (OPTIONAL)

The new generation EC-BRUSHLESS fans ensure a higher efficiency thanks to lower energy consumption compared to traditional AC motors.

The EC motors allow therefore lower sound emissions during the air flow modulation.

The blade profile has been studied to reduce noise and ensure high acoustic comfort levels.

NEW SUPERVISIONING CONTROL SYSTEM

The new generation and the most advanced control system entirely custom made able to manage and optimize the unit operation by coordinating the interaction between all the components: compressors, fans, inverter pumps and electronic expansion valves, maximizing the efficiency of the multi-functional system. It allows the interface with the main BMS system, via RS485, the routing on the web of all the operating parameters of the unit, allowing a total remote control of the unit through the Ethernet port RJ45, and the interface with the expansion modules I/O, via CanBus.

ENERGY SAVING

The unit can be turned off according to time bands. An innovative **Energy Saving** function can be also activated to regulate the on-off of the unit. By activating this function, at certain time bands, the controller will adjust the set point value to those required by the user. Thanks to the Energy saving the unit will be “forced to work more” at certain time when the cost of electricity is lower or even to work less when there is a lower heating load. The electronic control gives priority to the automatic shutdown, if the two functions should be active for the same daily time band.

MULTIPIPE CHILLER RTMA

2. OPERATING MODES

The multi-functional units are made by 2 distinct sections, the hot one at condenser side, and the cold one at evaporator side: the simultaneous production of hot and chilled water allows the unit to adapt its operation to any requirement of the plant, in a totally autonomous and self-managed way.

The multi-functional four pipes units automatically switch their operating cycle according to the load demands during the whole year, without doing the manual switch from summer to winter mode needed for the traditional heat pumps. There are three basic operating configuration which are automatically selected in order to minimize the power input and satisfy the thermal load of the plant.

ONLY CHILLER MODE

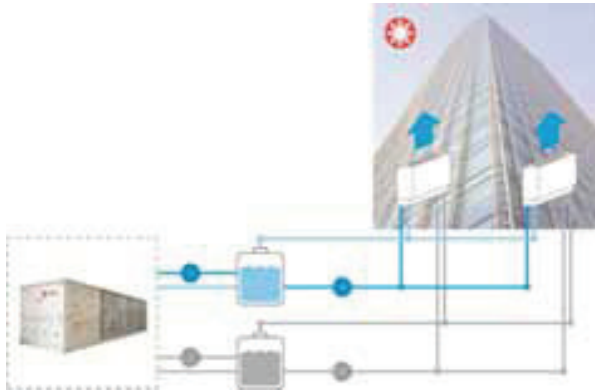

The unit works in chiller dissipating the condensation heat through a finned coil heat exchanger (condenser). The water is chilled in a water-refrigerant plate heat exchanger (evaporator).

ONLY HEAT PUMP MODE

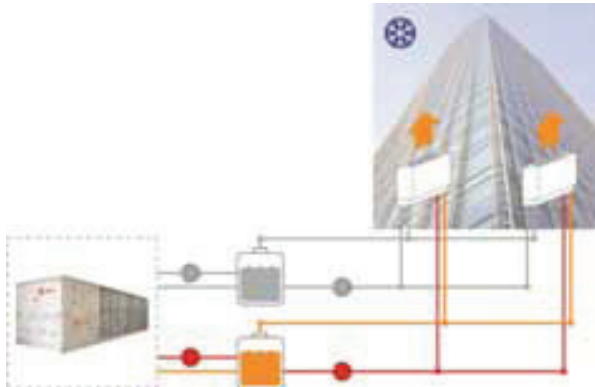

The unit works in heat pump mode only, exploiting the outdoor air energy to heat the water through a water-refrigerant plate heat exchanger (condenser). Differently from a traditional reversible heat pumps the hot water is produced through a different heat exchanger from those used to produce chilled water. Therefore according to the operating mode, whether the unit works in heat pump mode or in chiller mode, there will be a dedicated heat exchanger for the chilled or hot water production (evaporator or condenser). This is required in order to keep the cold and hot sections separated, as needed in a 4-pipe system.

CHILLER + TOTAL OR PARTIAL RECOVERY MODE



The unit works as a water-water heat pump if there's a simultaneous demand of hot and chilled water, by controlling the condensation and the evaporation through two different plates heat exchangers each for its own hydraulic circuit of the 4 pipe plant.

POSSIBLE OPERATING COMBINATIONS

HEATING LOAD (%)	COOLING LOAD (%)	CIRCUIT 1	CIRCUIT 2
100	100	C+R	C+R
75	25	H	C+R ^(PART LOAD)
50	50	R	OFF
50	25	H ^(PART LOAD)	C+R ^(PART LOAD)
25	0	H ^(PART LOAD)	OFF
75	0	H ^(PART LOAD)	H
100	0	H	H
50	100	C+R ^(PART LOAD)	C
25	75	C+R ^(PART LOAD)	C
50	50	OFF	C
100	50	H ^(PART LOAD)	C+R
50	75	C+R ^(PART LOAD)	C ^(PART LOAD)
50	25	H ^(PART LOAD)	C+R ^(PART LOAD)
50	0	H ^(PART LOAD)	OFF
25	75	C+R ^(PART LOAD)	C ^(PART LOAD)
25	50	C+R ^(PART LOAD)	C ^(PART LOAD)
25	25	C+R ^(PART LOAD)	OFF
25	0	H ^(PART LOAD)	OFF
0	100	C	C ^(PART LOAD)
0	75	C	C ^(PART LOAD)
0	50	OFF	C ^(PART LOAD)
0	25	OFF	C ^(PART LOAD)
0	0	OFF	OFF

H HEAT PUMP MODE
C+R CHILLER + RECOVERY MODE
C CHILLER MODE

MULTIPIPE CHILLER RTMA

3. UNIT DESIGNATION

The encoding of **RTMA** is simple and follows the rules defined by Trane for all other units:

Digit																											
1	2	3	4	5	6	7	8	9	10	11	12	13	14	15	16	17	18	19	20	21	22	23	24	25	26	27	28
R	T	M	A	1	3	0	S	1	1	1	1	1	1	1	1	2	1	1	1	1	1	1	1	1	1	1	1

Digits 1 to 4: RTMA = Screw compressor unit for Multi-pipe application

Digits 5 to 7 = Nominal tonnage

105 Tons - 368.7 kW
 115 Tons - 407.7 kW
 120 Tons - 426.0 kW
 130 Tons - 463.5 kW
 150 Tons - 529.2 kW
 170 Tons - 594.2 kW
 180 Tons - 626.2 kW
 190 Tons - 666.3 kW
 210 Tons - 733.0 kW

Digit 8 = Acoustics

X Standard Noise
 L Low Noise
 S Super Low Noise

Digit 9 = Hydraulic version

X Without (Standard)
 1 Cooling + Heating circuit pump 150 kPa
 2 Cooling + Heating circuit pump 250 kPa
 3 Cooling + Heating circuit pump 450 kPa
 4 Std by pump Cooling + Heating circuit pump 150 kPa
 5 Std by pump Cooling + Heating circuit pump 250 kPa
 6 Std by pump Cooling + Heating circuit pump 450 kPa

Digit 10 = Remote control display

X Without (Standard)
 1 With Remote Control Display

Digit 11 = Power factor correction

X Without (Standard)
 1 Cos Phi = 0.91

Digit 12 = Control panel electric heater with thermostat

X Without (Standard)
 1 With

Digit 13 = Phase failure protection relay

1 With (Standard)

Digit 14 = Communication card RS485

1 With (Standard)

Digit 15 = Soft starter

X Without (Standard)
 1 With

Digit 16 = Automatic circuit breaker

X Without (Standard)
 1 With

Digit 17 = Condensing control

X Standard
 1 With variable fan speed modulation
 2 EC Fans

Digit 18: Numbered wires

X Without (Standard)
 1 With

Digit 19: Flow switch

X Without (Standard)
 1 With

Digit 20 = Automatic water filling

X Without (Standard)
 1 With

Digit 21 = Water strainer

X Without (Standard)
 1 With

Digit 22 = Water gauges

X Without (Standard)
 1 With

Digit 23 = Gas gauges

X Without (Standard)
 1 With

Digit 24 = Condensing coil protection grilles

X Without (Standard)
 1 With

Digit 25 = Isolators

X Without (Standard)
 1 Rubber anti vibration mounts
 2 Spring anti vibration mounts

Digit 26 = Compressor sound jacket attenuator

X Without (Standard)
 1 With

Digit 27 = Condensing coil

1 Aluminum (Standard)
 2 Aluminum + Blygold condensing coils
 3 Aluminum Pre painted condensing coils
 4 Aluminum Epoxy coated condensing coils
 5 Copper/Copper condensing coils
 6 Tinned copper/copper condensing coils

Digit 28 = High temperature Hot leaving water (HPT)

X Without (Standard)
 1 With

TECHNICAL SPECIFICATIONS

The units belonging to **RTMA** range are multi-functional air cooled unit, for outdoor installation, equipped with screw compressors and axial fans, available in 9 sizes and in the following basic version:

RTMA units are available in a wide setting up ranges, in order to guarantee a high satisfaction level for different plant applications.

ACOUSTIC VERSIONS

LN version low noise unit, including condensing control with reduced fan speed (2 steps condensing control (Δ/Y) and soundproof insulation of the compressors box.

SL version: super low noise unit. The noise reduction is achieved by soundproof insulation of the compressors box, muffler on the compressor intake and delivery lines, oversized coils and additional fans speed modulation according to the condensing/evaporating pressure. For the SL unit, the hydraulic kit is equipped with soundproof box with acoustic insulation.

HYDRAULIC VERSIONS (Built.in hydraulic kit)

N.1 pump for chilled water circuit (150kPa) + N.1 pump for hot water circuit (150kPa)

N.1 pump for chilled water circuit (250kPa) + N.1 pump for hot water circuit (250kPa)

N.1 pump for chilled water circuit (450kPa) + N.1 pump for hot water circuit (450kPa)

CASING

Made of galvanized and painted steel with increased thickness and with thermoset polyurethane powder, dried in the oven. The main components (compressor and refrigerant circuit components) are contained in a closed box enclosure with different possibilities of acoustic insulation allowing a more easy ordinary and extraordinary maintenance of the components. A closed compartment, easily inspectable, protecting exchangers and pumps is located in the condensing section of the unit. The whole structure is made of galvanized and painted steel. The assembled base frame is composed by longitudinal and transverse components with a thickness of 3mm, coupled by high resistance nailing, the profile has a base of 80mm suitable to the mounting of spring or rubber shock absorbers through holes of 18mm. The structure is fixed to the uprights (thickness 2mm) with bolts and threaded inserts to facilitate their removal, the particular profile of the uprights allow the installation of inspection panels and grids embedded type to protect all the components and at the same time to allow easy and immediate access during any maintenance and service operation.

The painting treatment of the casing is made with epoxy powder, which gives the whole structure a long lasting resistance for outdoor installation, even in aggressive environmental conditions.

COMPRESSORS

Semi-hermetic twin screw helical oil injection, complete with oil separator built in three stages, the latest generation, and oil filter, both for increased efficiency. The compressor is birotore lobe with male and female with very high precision workmanship.

The five-lobe rotor is directly mounted on the two pole motor without the interposition of gearboxes. The bearings disposed on the axis of the rotors, in a special chamber isolated from the compression chamber, are made of carbon steel.

The screws with the innovative profile with N-type operation "rolling" allow you to obtain the maximum discharge at the lowest power consumption with an extremely low noise generation.

The robust mechanics allows to operate with efficiency in the entire field of application and in all speeds of rotation permitted. The bearings mounted in tandem with a high degree of rigidity and precision of operation and resistant to the combination of axial and radial loads, protect the vines against any rotations that might occur during system shutdown. These bearings have a special cages help to reduce noise and to increase the operational life of the compressors.

In the starting phase, since the pressures are always equalized inside the compressor, there is no circulation of oil, however, the bearings and the screws are designed to tolerate short periods (a few seconds) of operation "dry", waiting they establish the necessary pressure difference.

The three-stage oil separator ensures less migration of oil into the refrigerant circuit and at the same time better lubrication of the mechanical components of the compressors with a significant reduction in noise.

The semi-hermetic screw compressors are available, depending on size, with star-delta starting or dual stator winding separate "part winding", with a considerable reduction of inrush currents, which in an engine with direct starting values could reach three to 8 times higher than the maximum rated currents of operation. The semi-hermetic screw compressors are available with adjustment in steps or continuously with slide valve.

The first type of adjustment is obtained by the combination of three solenoid valves positioned in fixed positions on the body of the compressor that guarantee 4 steps of adjustment; the second is obtained from the combination of two solenoid valves, first one fixed position and the other one button, positioned also on the body of the compressor.

MULTIPIPE CHILLER RTMA

The capacity regulation is realized through a sliding drawer, "shutter", activated by oil pressure of the hydraulic circuit and controlled by solenoid valves positioned on the body of the compressor. The sliding drawer by acting on the volume aspirated by the bolts regulates the flow outlet and the cooling capacity generated by the compressor, resulting in a step change 25%, 50%, 75% and 100% in the first case, continuous from the minimum step at 100% in second. The cooling capacity control of the compressor allows increased performance at partial loads with a consequent increase in the value ESEER.

The perfect centering of the rotors, in the axial and radial, is ensured by bearings mounted to the ends of the shafts. The oil circuit will perform the following functions:

- Dynamic seal between the chambers
- Maintenance of a sliding drawer
- Lubricate the bearings and rotors
- Cooling of the moving parts
- Synchronization gea.

The oil circulation takes place by the pressure difference between the flow and the pressure of injection of oil, slightly higher than the suction pressure.

The oil and refrigerant mixture undergoes a first separation by virtue of the speed difference between the gas and the oil drops obtained for "Venturi" effect, a second separation as a result of centrifugal forces produced by special propellers and a third separation due to effect "filtering "through the parcel of the separator" Demister ", easily accessible and replaceable, in which the oil droplets are subject to continuous changes of direction and speed. The oil, thus separated, is collected inside the oil pan, leaving free the surface of the "Demister", while the gas flows through the discharge valve.

This innovative system ensures a pressure drop below 0.6 bar and a separation efficiency of 99.98% even in the most critical conditions.

The compressor is equipped with non-return valve to prevent internal, at shutdown, the rotors rotate in opposite directions.

The compressor is equipped with a safety valve that connects the areas of high and low pressure. The valve is sized according to EN 60335-2-34 and opens at a differential pressure of 26 bar.

The motors are equipped with an electronic protection device model INT 69 FRY that controls over the temperature of the windings and the temperature of the gas flow in through PTC thermistors and probes mounted on the windings and on the high pressure side also the correct direction of rotation and the presence of the three phases. In more guarantees a start delay of at least 5 minutes in the case of overheating of the windings and a maximum number of 10 starts now. Screw compressors used have wide limits of operation and high values of COP.

The limited number of moving parts, dramatically reduces maintenance.

Special features of screw compressors used are extremely quiet, no vibration and therefore reduced pressure at the inlet pipes discharge pipes, low maintenance.

The compressors are also equipped as standard with:

- Taps delivery
- Upload oil
- Crankcase heater
- Oil Flow.

FANS

The technology of Electronically Commutated motor Fans (EC Fans) propeller fans, has blades statically and dynamically balanced, driven directly by the electric motors, closed type, external rotor and thermal protection for outdoor installation. Class F windings, internal protection according to VDE 0730. Ecoprofile are characterized by low speed and "owlet" profile to reduce the effect of vortices, thereby reducing the energy consumed for operation and noise, reducing it by an average of 6dB (A) compared with standard fans. All the sizes are equipped with the 2 steps condensing control (Δ/Y).

HIGH EFFICIENCY SHELL AND TUBE HEAT EXCHANGER – COLD SIDE

Direct expansion shell and tube type, high efficiency with low temperature approach between fluid and refrigerant, to reduce the temperature difference and increasing the evaporation temperature, improving the efficiency and reducing the power consumption. The steel shell is provided with water connections victaulic and externally insulated with anti-condensate closed-cell (thickness of 10 mm and a thermal conductivity 0,033 W/mK a 0°C), in turn covered by a waterproof material resistant to UV rays.

The inner tubes are made of copper straight type with ruled surfaces, expanded on the tube plate of steel and complete with septa conveying water to optimize the thermal exchange. Designed for ecological fluids with speed inside the tubes is not less than 10m/sec, such as to ensure the proper oil carryover. The shell and tube heat exchanger is built and tested according to PED regulations. The heat exchanger is protected against the formation of ice through an immersion electrical heater, controlled directly by the microprocessor as a function of the temperature of the water leaving the evaporator, is also installed a differential water pressure switch appropriately selected depending on the exchanger pressure drops as security against the lack of flow.

HIGH EFFICIENCY SHELL AND TUBE HEAT EXCHANGER – HOT SIDE

Direct expansion shell and tube type, high efficiency with low temperature approach between fluid and refrigerant, to reduce the temperature difference and increasing the evaporation temperature, improving the efficiency and reducing the power consumption. The steel shell is provided with water connections victaulic and externally insulated with anti-condensate closed-cell (thickness of 10 mm and a thermal conductivity 0,033 W/mK a 0°C), in turn covered by a waterproof material resistant to UV rays.

The inner tubes are made of copper straight type with ruled surfaces, expanded on the tube plate of steel and complete with septa conveying water to optimize the thermal exchange. Designed for ecological fluids with speed inside the tubes is not less than 10m/sec, such as to ensure the proper oil carryover. The shell and tube heat exchanger is built and tested according to PED regulations.

The heat exchanger is protected against the formation of ice through an immersion electrical heater, controlled directly by the microprocessor as a function of the temperature of the water leaving the evaporator, is also installed a differential water pressure switch appropriately selected depending on the exchanger pressure drops as security against the lack of flow.

SOURCE HEAT EXCHANGER

The condensing / evaporating exchangers are with finned coil and copper tubes, with corrugated fins of aluminum with spacing of the tubes 30/26 and spacing fins differentiated with fin pitch of 1.6mm at the top and 2.5mm at the bottom. Thanks to the differentiated spacing is obtained a uniform speed profile across the coils so as to increase the heat exchange in the lower part especially critical in heat pumps.

On the basis of the coils are installed thermostated electrical heaters, immersed in the last row of tubes, in such a way that the heat develops around the entire pipe by increasing the conduction of heat. These electrical heaters are useful to prevent formation of ice on the batteries and to reduce the defrosting time favoring the drainage of the condensate.

Copper tubes are mechanically expanded, and are of a high efficiency with CROSS-GROOVED tube.

The batteries are also designed for ecological fluids, the velocity inside the tubes, not less than 10m/sec, are such as to ensure the correct entrainment of the oil in each load condition.

REFRIGERANT CIRCUIT

The refrigerant circuit is specific and optimized for the use of a reduced number of solenoids valve and the cross exchange technology, which allows to avoid stops of the units during winter times in case of hot water demand only when cooling is satisfied . Consequently the water temperature of the cold tank doesn't reach the temperature of ice on the evaporator.

The units are equipped with two independent refrigerant circuits, entirely constructed with copper tubes, each supplied by its own compressor, including:

- Refrigerant charge R134a
- Electronic expansion valve with stepper motor, suitable for ecologic refrigerant, with the control of the superheating within the whole operating range of the unit.
- Filter drier with interchangeable cartridge suitable for the use of ecological fluids and polyesters oils;
- Indicator lamp for liquid flow and humidity presence;
- Shut off valve on the liquid line complete of balancing pressure system making easier the opening and closing operations;
- High pressure switch;
- Low pressure switch;
- Pressure switch for the compressor oil to control the filter block;
- Safety valve on the discharge line;
- Safety valve on the suction line;
- High pressure trasducer;
- Low pressure transducers;
- Compressors discharge valve;
- Liquid receiver;
- Oil separator;
- 4 way reverse valve;
- Cycle configuration valve.

MULTIPIPE CHILLER RTMA

ELECTRICAL PANEL

The electrical panel made in accordance with CEI-EN 60204-1 (CEI44-5; CEI EN 62061) standards, is housed in watertight box, the opening system of the box needs the use of a retractable handle or dedicated tools, in each case the opening is allowed only after disconnection of the power supply through the main switch with door lock handle lockable in OFF position.

The electrical panel includes:

- Protection fuses for the supply line of each compressor;
- Protection fuses for the supply line of fans for each refrigerant circuit;
- Protection fuses of auxiliary circuit;
- Start up contactors for compressors dimensioned according to the maximum stress;
- Start up contactors for fans
- Adjustable thermal magnetic circuit breaker for the protection of the pump (only in case of units equipped with hydraulic kit)
- Start up contactors for pump (only in case of units equipped with hydraulic kit)
- single-phase transformer for the power supply of the auxiliary circuits
- numbered wires
- microprocessor control

In case of phase failure an automatic system protects fans and compressors.

The wiring of the electric panel and the connection with the components of the units are made using cables appropriately calculated for operation at 55°C and according to the maximum electrical stress of the components.

All the cables and the terminals are univocally numbered according to the electrical scheme in order to avoid possible misinterpretation. The identification system of the cables connected to the components allow also an easy and intuitive recognition of the component.

Each component of the electrical panel is provided with an identification plate according to what is shown on the electrical scheme. All the connection to the electrical panel are made from the bottom and are equipped with cover preventing from break.

The electrical panel supply is 400V/3ph+n/50Hz and no additional power supply is necessary. The input of the power cables is provided on the bottom of the box where it is provided a dismantable flange suitable for the purpose.

MICROPROCESSOR CONTROL SYSTEM



The multi-functional four pipes unit, are equipped with two completely independent circuits, controlled by 2 devices, each of which handles a single circuit. The two devices are in communication with each other via the Modbus protocol. The keypad allows a complete and intuitive display of all the main control variables of both circuits .

The programmable controller is based on a powerful platform with 256bit microprocessor, 4MB mass storage with a hardware and software configuration made with the most innovative technology in terms of processing speed and connectivity.

The diagnostics includes a complete alarm management, alarm history and data logger which stores an archive of about 4 days (further expandable by USB memory) where the main variables and the operating status of the unit are recorded. ModBus master and slave communication protocol. The temperature regulation us carried out by two hydraulic circuits (cooled water and hot water), with a continuous proportional logic according to the return water temperature.

The operating parameters of the machine are protected by 3 levels of password (user-maintainer-builder). The user panel provides information LCD display with exhaustive descriptions in Italian and English (selectable).

- Ability to interface with the main BMS systems via RS485.
- Ability to interface with I/O expansion modules via CanBus
- Ability to control the unit by voltage free contacts
- Input Ethernet RJ45, for routing on the web of all the parameters of the unit, providing a total remote control of unit.

- USB input to upload parameter files, system files, firmware and to download files of historical alarms, residing parameters files and default parameters files.
- User interface on the door of the panel, low-reflection LCD, equipped with 8 function keys, easy iconic display, easy sliding between the dynamic screens.
- Control of condensation / evaporation air through two speed fans directly managed by the electronic controller based on proportional logic (LN version).
- Control of condensation / evaporation air through inverter directly managed by the electronic controller based on proportional logic (SL version).
- Management of electronic expansion valves through controller based on PID logic, with LOP control (low operating pressure), maintenance of the minimum working pressure and of the MOP (maximum operating pressure) for the management of the maximum working pressure.

The microprocessor manages:

- Star-Delta starting of the compressors with digital control of the interchange time and with the start-up and stop time control
- Part-Winding starting of the compressors with digital control of the interchange time and with the start-up and stop time control
- Solenoid valves for compressors partialization with digital control of delays
- Fans start up and modulation according with condensation and evaporation pressure.
- Solenoid valves of liquid lines with pump-down management during stops through double control of suction pressure and maximum time of the procedure.
- Electric anti-freeze heater for user exchangers.
- Electric heater mounted on the base of coils to avoid ice formation.
- Hot and cold side water pumps management through voltage free contacts for standard versions; for hydraulic versions the pump management is automatically controlled.
- Alarm signal for each refrigerant circuit of the unit through voltage free contacts.

The microprocessor will control and display by suitable measuring transducers the following variables:

- Inlet and outlet water temperature to the cold user exchanger
- Inlet and outlet water temperature to the hot user exchanger
- Outdoor temperature
- Condensing pressure of each refrigerant circuit.
- Evaporating pressure of each refrigerant circuit.
- Total operating time of each compressor.
- Total operating time of the unit.

The microprocessor will protect the unit in the following cases, the resetting of any alarm will always be manual:

- Low evaporating pressure by analogical and digital input with possibility to edit the marking details.
- High condensing pressure by analogical and digital input.
- High temperature of the compressors windings.
- Reverse rotation of each compressor
- Low pressure difference between discharge and suction (to allow a correct lubrication of the compressor) with the possibility to edit the start-up delay and the minimum requested value.
- High pressure difference on the oil filter.
- High temperature of fans motor windings.
- High temperature of pumps motor windings
- Lack of water flow on evaporator and condenser.
- Low evaporator outlet water temperature
- Low condenser outlet water temperature

It is also possible to display and edit through the microprocessor the following value:

- Operating setpoint of the unit
- Operating differential of the unit.
- Set point and anti-freeze block differential.
- Set point and differential of activation of the evaporator heater.
- Minimum operating time of each compressor.
- Minimum stop time of each compressor.
- Maximum number of starts per hour of each compressor.
- Set point and optimal condensation pressure differential (condensation and evaporation control)

Other functionalities ensured from the microprocessor are:

- Activating of preventive functions at extreme conditions of high pressure
- Activating of preventive functions at extreme conditions of low pressure
- Activation of preventive functions at limit conditions of high discharge temperature.
- Activating preventive functions at extreme conditions of low evaporator leaving water temperature.
- Activating preventive functions at extreme conditions of high evaporator inlet water temperature.
- Protection from unwanted changes of the parameters thanks of the use of password and systems to confirm the changed data.

- Indication of the unit status and the components status.
- Possibility to exclude each compressor for the maintenance.
- Possibility to change the set point by external analog signal.
- Possibility of ON/OFF remote signal through digital external signal.
- Communication with supervision systems (data and parameters exchange)
- Continuous adjustment of the set point according to the outdoor air temperature both with direct and reverse direction logic (DSP).
- Intelligent management of defrosts depending on the approach of the coil (Digital Defrost).
- Auto power on-off of the unit using time slots.
- Adjustment of the set point by time bands both with direct and reverse direction logic (Energy Saving).

4. ACCESSORIES ON DEMAND

MOUNTED ACCESSORIES

- Stand by pump for air conditioning circuit + stand by pump for heating circuit ,150 kPa
- Stand by pump for air conditioning circuit + stand by pump for heating circuit ,250 kPa
- Stand by pump for air conditioning circuit + stand by pump for heating circuit ,450 kPa
- High temperature performance for production water temperatures up to 65°C
- Power factor correction to cos phi 0.91
- Control panel electric heater with thermostat
- Condensing control with variable fan speed modulation
- Electronically Commutated Motor fans (EC Fans)
- Numbered wires
- Gas gauges kit
- Automatic circuit breakers
- Condensing coil protection grilles.
- Pre-painted condensing coils
- Epoxy coated condensing coils fins.
- Copper/copper condensing coils.
- Tinned copper/copper condensing coils.
- BLYGOLD treats coils.
- Soft Start

LOOSE ACCESSORIES

- Remote control display
- Flow switch
- Automatic water filling
- Threaded stainer
- Water gauges kit
- Rubber anti-vibration mounts.
- Spring anti-vibration mounts

5. ENERGY EFFICIENCY RATIOS

METHODOLOGY FOR CALCULATING SEASONAL ENERGY EFFICIENCY

Energy efficiency of the multifunction unit heat pump **RTMA**, in chiller operating mode, is calculated according the ESEER coefficient. Considering that all have recognized the IPLV lack of adaptability in front of needs in Europe, it is developed a new coefficient, called ESEER (European Seasonal Energy Efficiency Ratio), that is much more equal to EMPE Italian coefficient than the IPLV coefficient.

The formula of the three coefficient is:

$$\text{Index} = \text{PE100\% EER100\%} + \text{PE75\% EER75\%} + \text{PE50\% EER50\%} + \text{PE25\% EER25\%}$$

FEATURES	INDEX	LOAD (100%)	LOAD (75%)	LOAD (50%)	LOAD (25%)
Energetic weight	IPLV	1%	42%	45%	12%
	EMPE	10%	30%	40%	20%
	ESEER	3%	33%	41%	23%
T _{in air/condenser} air-water unit	IPLV	35°C	26,7°C	18,3°C	12,8°C
	EMPE	35°C	31,3°C	27,5°C	23,8°C
	ESEER	35°C	30°C	25°C	20°C
T _{in water/condenser} water-water unit	IPLV	29,5°C	23,9°C	18,3°C	18,3°C
	EMPE	29,5°C	26,9°C	24,4°C	21,9°C
	ESEER	30°C	25°C	20°C	20°C

TEC – TOTAL EFFICIENCY COEFFICIENT

The effective coefficient measuring the unit performance during the whole year is the TEC (Total Efficiency COEFFICIENT), an index properly properly developed to measure the multifunction real efficiency.

The TEC indicator is an average year efficiency index considering the efficiency of each operating mode of the unit properly weighted (cooling, cooling + heating, heating), more completely than the standard full-load efficiency ratios (EER, COP) and seasonal one (ESEER).

Usually the multifunctional units have TEC value around 5. This means that per each kW of power input there is a useful capacity of 5.

$$\text{TEC} = (\text{EER}_{\text{COOLING}} * \alpha + \text{DMEC}_{\text{COOLING+HEATING}} * \beta + \text{COP}_{\text{HEATING}} * \gamma)$$

Where:

α = weight for only chiller mode operation (%)

β = weight for chiller + heating mode operation (%)

γ = weight for only heating mode operation (%)

DMEC = Dual Mode Efficiency Coefficient = Efficiency in chiller + recovery mode

The DMEC index is the ratio between the sum of the heating and cooling capacity and the compressors electrical power input, in chiller + recovery mode, and reaches the maximum value when the heating and cooling loads are fully balanced. It allows to calculate.

This index was defined to objectively measure the efficiency of a multi-functional unit according to simultaneous load requirement.

MULTIPIPE CHILLER RTMA

6. TECHNICAL DATA

GENERAL TECHNICAL DATA

RTMA

RTMA		105	115	120	130	150	170	180	190	210
Cooling (1)										
Total cooling capacity	kW	368,7	407,7	426	463,5	529,2	594,2	626,2	666,3	733
Compressors power input	kW	113,5	127,2	131	137,1	156,1	168,8	182,4	193,4	214
Total EER		2,9	2,9	2,9	3	3	3,2	3,1	3,1	3,12
Water flow	m ³ /h	63,4	70,1	73,3	79,7	91,0	102,2	107,7	114,6	126,1
Water pressure drop	kPa	68,8	49,5	51,4	57,1	68,2	81,5	87,9	39,0	46,3
Heating (2)										
Total heating capacity	kW	411,8	464,1	484,1	527,5	594,1	675,7	699,4	718,1	811,9
Compressors power input	kW	113	127,9	133,4	137,9	153,8	172,3	183,4	194	211,9
Total COP		3,3	3,3	3,4	3,4	3,5	3,6	3,5	3,3	3,5
Water flow	m ³ /h	70,8	79,8	83,3	90,7	102,2	116,2	120,3	123,5	139,6
Water pressure drop	kPa	85,8	64,1	66,3	73,9	86,0	105,5	109,6	45,3	56,8
Heating + Cooling (3)										
Total cooling capacity	kW	368,7	407,7	426	463,5	529,2	594,2	626,2	666,3	733
Total heating capacity	kW	482,2	534,9	557	600,6	685,3	763	808,6	859,7	947
Compressors power input	kW	113,5	127,2	131	137,1	156,1	168,8	182,4	193,4	214
DMEC		7,5	7,4	7,5	7,8	7,8	8	7,9	7,9	7,9
TEC		5,3	5,3	5,4	5,5	5,5	5,7	5,6	5,6	5,6
Evaporator water flow	m ³ /h	63,4	70,1	73,3	79,7	91	102,2	107,7	114,6	126,1
Evaporator pressure drop	kPa	68,8	49,5	51,4	57,1	68,2	81,5	87,9	39,0	46,3
Condenser water flow	m ³ /h	82,9	92	95,8	103,3	117,9	131,2	139,1	147,9	162,884
Condenser pressure drop	kPa	117,6	85,2	87,8	95,8	114,4	134,5	146,5	64,9	77,2
COMPRESSORS										
Compressors number	n	2	2	2	2	2	2	2	2	2
Refrigerant circuits	n	2	2	2	2	2	2	2	2	2
Part load	n	6	6	6	6	6	6	6	6	6
Refrigerant charge	kg	117	124	136	152	173	185	192	205	222
Oil charge	kg	20	20	34	34	34	34	34	34	40
FANS										
Fans number	n	8	8	10	10	12	12	12	14	14
Air flow	m ³ /h	164480	155200	206000	206000	235200	235200	235200	28140	281400
Power input for each fan	kW	1,5	1,5	1,5	1,5	1,5	1,5	1,5	1,5	1,5
Absorbed current for each fan	A	3	3	3	3	3	3	3	3	3
SOUND LEVEL										
Sound power level (ISO 3744)	db(A)	92	92	93	93	95	95	95	96	96
Sound pressure level at 10 m (ISO 3744)	db(A)	61	61	62	62	64	64	64	65	65
DIMENSIONS AND WEIGHT										
Length	mm	5431	5431	6601	6601	7561	7561	7561	8892	8892
Depth	mm	2250	2250	2250	2250	2250	2250	2250	2250	2250
Height	mm	2400	2400	2400	2400	2400	2400	2400	2400	2400
Operating Weight	kg	5592	5799	6057	6121	6578	6925	6946	7199	7794
Shipping Weight	kg	5242	5449	5728	5792	6248	6607	6628	6891	7486

(1) Outdoor air temperature 35 °C – Outlet water temperature 12/7 °C

(2) Outdoor air temperature 7 °C - 90% UR - Outlet water temperature 45 °C

(3) Recovery water temperature 40/45 °C – Evaporator water temperature 12/7 °C

GENERAL TECHNICAL DATA

RTMA LN		105	115	120	130	150	170	180	190	210
Cooling (1)										
Total cooling capacity	kW	355,7	395,2	413,3	449,5	516	579,2	609,9	649,8	714,8
Compressors power input	kW	116,9	130,8	127,3	141,4	161,1	174,2	188,3	199,6	220,8
Total EER		2,76	2,77	2,9	2,87	2,88	3,01	2,96	2,95	2,96
Water flow	m ³ /h	61,2	68,0	71,1	77,3	88,8	99,6	104,9	111,8	122,9
Water pressure drop	kPa	64,0	46,5	48,4	53,7	64,9	77,5	83,4	37,1	44,0
Heating (2)										
Total heating capacity	kW	416,4	469,3	489,6	533	600	682,4	706,4	725,2	820
Compressors power input	kW	113,3	128,3	126,5	138,3	154,2	172,7	183,8	194,5	212,4
Total COP		3,32	3,35	3,46	3,48	3,48	3,58	3,5	3,37	3,51
Water flow	m ³ /h	71,6	80,7	84,2	91,7	103,2	117,4	121,5	124,7	141,0
Water pressure drop	kPa	87,7	65,6	67,9	75,5	87,7	107,5	111,8	46,2	57,9
Heating + Cooling (3)										
Total cooling capacity	kW	368,7	407,7	426,0	463,5	529,2	594,2	626,2	666,3	733,0
Total heating capacity	kW	482,2	534,9	557,0	600,6	685,3	763,0	808,6	859,7	947,0
Compressors power input	kW	113,5	127,2	131,0	137,1	156,1	168,8	182,4	193,4	214,0
CMEC		7,50	7,41	7,50	7,76	7,78	8,04	7,87	7,89	7,85
TEC		5,30	5,26	5,37	5,50	5,51	5,70	5,57	5,54	5,57
Evaporator water flow	m ³ /h	63,4	70,1	73,3	79,7	91,0	102,2	107,7	114,6	126,1
Evaporator pressure drop	kPa	68,8	49,5	51,4	57,1	68,2	81,5	87,9	39,0	46,3
Condenser water flow	m ³ /h	82,9	92,0	95,8	103,3	117,9	131,2	139,1	147,9	162,9
Condenser pressure drop	kPa	117,6	85,2	87,8	95,8	114,4	134,5	146,5	64,9	77,2
COMPRESSORS										
Compressors number	n	2	2	2	2	2	2	2	2	2
Refrigerant circuits	n	2	2	2	2	2	2	2	2	2
Part load	n	6	6	6	6	6	6	6	6	6
Refrigerant charge	kg	117	124	136	152	173	185	192	205	222
Oil charge	kg	20	20	34	34	34	34	34	34	40
FANS										
Fans number	n	8	8	10	10	12	12	12	14	14
Air flow	m ³ /h	164480	155200	206000	206000	235200	235200	235200	281400	281400
Power input for each fan	kW	1,5	1,5	1,5	1,5	1,5	1,5	1,5	1,5	1,5
Absorbed current for each fan	A	3	3	3	3	3	3	3	3	3
SOUND LEVEL										
Sound power level (ISO 3744)	db(A)	90	90	91	91	93	93	93	94	94
Sound pressure level at 10 m (ISO 3744)	db(A)	59	59	60	60	62	62	62	63	63
DIMENSIONS AND WEIGHT										
Length	mm	5431	5431	6601	6601	7561	7561	7561	8892	8892
Depth	mm	2250	2250	2250	2250	2250	2250	2250	2250	2250
Height	mm	2400	2400	2400	2400	2400	2400	2400	2400	2400
Operanting Weight	kg	5592	5799	6057	6121	6578	6925	6946	7199	7794
Shipping Weight	kg	5242	5449	5728	5792	6248	6607	6628	6891	7486

(1) Outdoor air temperature 35 °C – Outlet water temperature 12/7 °C

(2) Outdoor air temperature 7 °C - 90% UR - Outlet water temperature 45 °C

(3) Recovery water temperature 40/45 °C – Evaporator water temperature 12/7 °C

MULTIPIPE CHILLER RTMA

GENERAL TECHNICAL DATA

RTMA SL

RTMA SL		105	115	120	130	150	170	180	190	210
Cooling (1)										
Total cooling capacity	kW	365,1	404,2	422,5	459,6	525,6	590,1	621,7	661,8	728
Compressors power input	kW	114,4	128,2	124,8	138,3	157,5	170,3	184	195,1	215,9
Total EER		2,97	2,96	3,12	3,09	3,09	3,23	3,16	3,15	3,16
Water flow	m ³ /h	62,8	69,5	72,7	79,1	90,4	101,5	106,9	113,8	125,2
Water pressure drop	kPa	67,4	48,6	50,5	56,1	67,3	80,4	86,6	38,4	45,6
Heating (2)										
Total heating capacity	kW	419,5	472,9	493,3	536,7	604	686,9	711,1	730	825,4
Compressors power input	kW	113,6	128,6	126,8	138,5	154,4	173	184,1	194,8	212,8
Total COP		3,44	3,45	3,59	3,6	3,62	3,7	3,61	3,48	3,63
Water flow	m ³ /h	72,2	81,3	84,9	92,3	103,9	118,1	122,3	125,6	142,0
Water pressure drop	kPa	89,1	66,6	68,9	76,5	88,9	109,0	113,3	46,8	58,7
Heating + Cooling (3)										
Total cooling capacity	kW	368,7	407,7	426,0	463,5	529,2	594,2	626,2	666,3	733,0
Total heating capacity	kW	482,2	534,9	557,0	600,6	685,3	763,0	808,6	859,7	947,0
Compressors power input	kW	113,5	127,2	131,0	137,1	156,1	168,8	182,4	193,4	214,0
DMEC		7,50	7,41	7,50	7,76	7,78	8,04	7,87	7,89	7,85
TEC		5,37	5,33	5,45	5,58	5,59	5,78	5,65	5,62	5,64
Evaporator water flow	m ³ /h	63,4	70,1	73,3	79,7	91,0	102,2	107,7	114,6	126,1
Evaporator pressure drop	kPa	68,8	49,5	51,4	57,1	68,2	81,5	87,9	39,0	46,3
Condenser water flow	m ³ /h	82,9	92,0	95,8	103,3	117,9	131,2	139,1	147,9	162,9
Condenser pressure drop	kPa	117,6	85,2	87,8	95,8	114,4	134,5	146,5	64,9	77,2
COMPRESSORS										
Compressors number	n	2	2	2	2	2	2	2	2	2
Refrigerant circuits	n	2	2	2	2	2	2	2	2	2
Part load	n	6	6	6	6	6	6	6	6	6
Refrigerant charge	kg	117	124	136	152	173	185	192	205	222
Oil charge	kg	20	20	34	34	34	34	34	34	40
FANS										
Fans number	n	8	8	10	10	12	12	12	14	14
Air flow	m ³ /h	128000	128000	160000	160000	192000	192000	192000	224000	224000
Power input for each fan	kW	1,05	1,05	1,05	1,05	1,05	1,05	1,05	1,05	1,05
Absorbed current for each fan	A	2,1	2,1	2,1	2,1	2,1	2,1	2,1	2,1	2,1
SOUND LEVEL										
Sound power level (ISO 3744)	db(A)	87,0	87,0	88,0	88,0	90,0	90,0	90,0	91,0	91,0
Sound pressure level at 10 m (ISO 3744)	db(A)	56,0	56,0	57,0	57,0	59,0	59,0	59,0	60,0	60,0
DIMENSIONS AND WEIGHT										
Length	mm	5431	5431	6601	6601	7561	7561	7561	8892	8892
Depth	mm	2250	2250	2250	2250	2250	2250	2250	2250	2250
Height	mm	2400	2400	2400	2400	2400	2400	2400	2400	2400
Operanting Weight	kg	5872	6079	6387	6451	6948	7295	7316	7619	8214
Shipping Weight	kg	5522	5729	6058	6122	6618	6977	6998	7311	7906

(1) Outdoor air temperature 35 °C – Outlet water temperature 12/7 °C

(2) Outdoor air temperature 7 °C - 90% UR - Outlet water temperature 45 °C

(3) Recovery water temperature 40/45 °C – Evaporator water temperature 12/7 °C

PERFORMANCE TABLE

COOLING CAPACITY PERFORMANCE

RTMA

Twout			105						115					
			Tae						Tae					
			25°C	30°C	32°C	35°C	40°C	43°C	25°C	30°C	32°C	35°C	40°C	43°C
6°C	Pf	kW	418,1	387,0	374,1	354,5	321,7	302,3	454,5	425,2	413,1	394,4	362,7	343,7
	Pa	kW	95,5	103,1	106,5	111,8	121,3	127,5	108,6	116,4	119,9	125,4	135,4	141,8
	qw	m ³ /h	71,91	66,56	64,34	60,97	55,33	52,00	78,18	73,14	71,05	67,84	62,39	59,11
	dpw	kPa	88,4	75,8	70,8	63,6	52,4	46,2	61,5	53,8	50,8	46,3	39,2	35,2
7°C	Pf	kW	433,8	402,0	388,8	368,7	335,0	315,1	469,1	439,2	426,8	407,7	375,3	355,8
	Pa	kW	97,0	104,8	108,1	113,5	123,2	129,3	110,3	118,2	121,7	127,2	137,3	143,8
	qw	m ³ /h	74,62	69,14	66,87	63,42	57,63	54,19	80,69	75,54	73,40	70,12	64,55	61,19
	dpw	kPa	95,2	81,7	76,5	68,8	56,8	50,2	65,5	57,4	54,2	49,5	41,9	37,7
8°C	Pf	kW	450,0	417,4	403,8	383,3	348,7	328,2	483,9	453,4	440,7	421,2	388,1	368,1
	Pa	kW	98,6	106,4	109,8	115,2	125,0	131,2	112,1	120,0	123,5	129,0	139,2	145,7
	qw	m ³ /h	77,40	71,78	69,46	65,92	59,98	56,45	83,24	77,99	75,80	72,45	66,76	63,32
	dpw	kPa	102,4	88,1	82,5	74,3	61,5	54,5	69,7	61,2	57,8	52,8	44,8	40,3
9°C	Pf	kW	466,5	433,1	419,3	398,2	362,8	341,7	499,0	467,9	454,9	435,0	401,2	380,7
	Pa	kW	100,2	108,1	111,5	117,0	126,8	133,2	113,9	121,8	125,3	130,9	141,1	147,7
	qw	m ³ /h	80,24	74,49	72,11	68,49	62,39	58,77	85,84	80,47	78,24	74,82	69,00	65,48
	dpw	kPa	110,1	94,9	88,9	80,2	66,6	59,1	74,1	65,2	61,6	56,3	47,9	43,1
10°C	Pf	kW	483,4	449,2	435,1	413,5	377,1	355,5	514,4	482,6	469,3	449,0	414,4	393,5
	Pa	kW	101,8	109,8	113,2	118,8	128,7	135,1	115,7	123,6	127,2	132,8	143,0	149,7
	qw	m ³ /h	83,14	77,27	74,83	71,12	64,87	61,14	88,48	83,00	80,72	77,23	71,28	67,68
	dpw	kPa	118,2	102,1	95,8	86,5	72,0	63,9	78,8	72,4	68,5	62,7	53,4	48,2
11°C	Pf	kW	500,6	465,7	451,2	429,1	391,9	369,6	530,0	497,5	484,0	463,3	427,9	406,5
	Pa	kW	103,5	111,5	115,0	120,5	130,6	137,0	117,5	125,5	129,0	134,7	145,0	151,7
	qw	m ³ /h	86,11	80,10	77,61	73,81	67,40	63,57	91,16	85,58	83,25	79,68	73,60	69,92
	dpw	kPa	126,8	109,7	103,0	93,2	77,7	69,1	83,6	73,7	69,7	63,9	54,5	49,2

Tae = Outdoor air temperature(°C);
Twout = Outlet water temperature (°C);
Pf = Cooling capacity (kW);
Pa = Compressors power input (kW) ;
qw = Water flow (m³/h);
dpw = Pressure drop (kPa).

Water flow and pressure drop on heat exchanger calculated with $\Delta T= 5\text{ }^{\circ}\text{C}$.

MULTIPIPE CHILLER RTMA

COOLING CAPACITY PERFORMANCE

RTMA

Twout			120						130					
			Tae						Tae					
			25°C	30°C	32°C	35°C	40°C	43°C	25°C	30°C	32°C	35°C	40°C	43°C
6°C	Pf	kW	472,9	443,4	431,0	412,0	379,6	360,0	513,7	481,4	467,9	447,2	411,8	390,4
	Pa	kW	105,8	113,3	116,6	122,0	131,7	138,0	115,2	124,6	128,7	135,2	147,2	155,0
	qw	m³/h	81,34	76,26	74,14	70,87	65,29	61,92	88,36	82,79	80,47	76,91	70,84	67,16
	dpw	kPa	63,3	55,7	52,6	48,1	40,8	36,7	70,1	61,5	58,1	53,1	45,1	40,5
7°C	Pf	kW	488,2	458,0	445,4	426,0	392,8	372,7	531,8	498,6	484,8	463,5	427,2	405,1
	Pa	kW	107,6	115,1	118,4	132,9	133,6	139,9	116,8	126,3	130,4	137,1	149,3	157,2
	qw	m³/h	83,97	78,78	76,61	73,27	67,57	64,11	91,47	85,77	83,38	79,72	73,47	69,67
	dpw	kPa	67,5	59,4	56,2	51,4	43,7	39,3	75,1	66,0	62,4	57,1	48,5	43,6
8°C	Pf	kW	503,7	473,0	460,0	440,2	406,3	385,8	550,4	516,3	502,1	480,2	442,8	420,1
	Pa	kW	109,3	116,9	120,2	125,6	135,5	141,9	118,5	128,0	132,3	139,0	151,3	159,3
	qw	m³/h	86,64	81,35	79,13	75,72	69,89	66,35	94,66	88,81	86,36	82,60	76,17	72,25
	dpw	kPa	71,8	63,3	59,9	54,9	46,7	42,1	80,5	70,8	67,0	61,3	52,1	46,9
9°C	Pf	kW	519,6	488,1	475,0	454,7	420,1	399,0	569,3	534,4	519,8	497,3	458,9	435,4
	Pa	kW	111,1	118,7	122,1	127,5	137,4	143,9	120,2	129,8	134,1	140,9	153,4	161,5
	qw	m³/h	89,37	83,96	81,69	78,21	72,25	68,63	97,92	91,92	89,41	85,54	78,93	74,89
	dpw	kPa	76,4	67,5	63,9	58,5	50,0	45,1	86,1	75,9	71,8	65,7	55,9	50,4
10°C	Pf	kW	535,7	503,6	490,1	469,4	434,0	412,5	588,7	552,9	537,9	514,9	475,3	451,1
	Pa	kW	112,9	120,5	123,9	129,4	139,4	145,9	121,9	131,6	136,0	142,8	155,5	163,7
	qw	m³/h	92,13	86,61	84,30	80,74	74,65	70,95	101,26	95,10	92,52	88,56	81,75	77,59
	dpw	kPa	81,2	71,8	68,0	62,4	53,3	48,2	92,1	95,1	90,0	82,4	70,3	63,3
11°C	Pf	kW	552,0	519,3	505,5	484,4	448,3	426,3	608,6	571,9	556,5	532,8	492,1	467,2
	Pa	kW	114,7	122,4	125,8	131,3	141,3	147,9	123,7	133,5	137,8	144,8	157,6	165,9
	qw	m³/h	94,95	89,32	86,95	83,32	77,10	73,32	104,68	98,36	95,71	91,64	84,64	80,36
	dpw	kPa	90,1	79,7	75,5	69,4	59,4	53,7	102,7	90,7	85,9	78,7	67,2	60,5

- Tae** = Outdoor air temperature(°C);
Twout = Outlet water temperature (°C);
Pf = Cooling capacity (kW);
Pa = Compressors power input (kW) ;
qw = Water flow (m³/h);
dpw = Pressure drop (kPa).

Water flow and pressure drop on heat exchanger calculated with $\Delta T= 5\text{ }^{\circ}\text{C}$.

COOLING CAPACITY PERFORMANCE
RTMA

Twout			150						170					
			Tae						Tae					
			25°C	30°C	32°C	35°C	40°C	43°C	25°C	30°C	32°C	35°C	40°C	43°C
6°C	Pf	kW	572,8	544,5	532,3	513,3	479,5	458,2	643,7	611,6	597,8	576,2	538,0	513,9
	Pa	kW	131,7	141,9	146,5	154,0	168,1	177,5	142,2	153,4	158,4	166,6	181,9	192,1
	qw	m³/h	98,52	93,65	91,56	88,29	82,48	78,81	110,72	105,19	102,82	99,11	92,54	88,38
	dpw	kPa	79,9	72,2	69,0	64,2	56,0	51,1	95,7	86,4	82,5	76,7	66,9	61,0
7°C	Pf	kW	590,5	561,3	548,8	529,2	494,4	472,4	663,7	630,6	616,4	594,2	554,8	529,9
	Pa	kW	133,5	143,9	148,5	156,1	170,3	179,8	144,2	155,5	160,5	168,8	184,3	194,6
	qw	m³/h	101,56	96,55	94,40	91,02	85,04	81,25	114,16	108,47	106,03	102,20	95,43	91,15
	dpw	kPa	84,9	76,8	73,4	68,2	59,5	54,4	101,7	91,8	87,8	81,5	71,1	64,9
8°C	Pf	kW	608,5	578,5	565,7	545,5	509,6	486,9	684,2	650,1	635,5	612,6	572,0	546,3
	Pa	kW	135,5	145,8	150,5	158,2	172,6	182,2	146,2	157,6	162,7	171,1	186,7	197,1
	qw	m³/h	104,67	99,51	97,29	93,82	87,65	83,75	117,67	111,81	109,30	105,36	98,38	93,97
	dpw	kPa	90,2	81,5	77,9	72,5	63,3	57,7	108,1	97,6	93,3	86,7	75,6	68,9
9°C	Pf	kW	627,0	596,1	582,9	562,1	525,1	501,7	705,1	670,0	654,9	631,4	589,6	563,1
	Pa	kW	137,4	147,9	152,6	160,3	174,9	184,6	148,3	159,8	164,9	173,4	189,2	199,7
	qw	m³/h	107,85	102,53	100,25	96,67	90,32	86,30	121,27	115,24	112,65	108,60	101,40	96,85
	dpw	kPa	95,8	86,6	82,8	77,0	67,2	61,3	114,8	103,7	99,1	92,1	80,3	73,2
10°C	Pf	kW	645,9	614,1	600,4	579,0	541,0	516,9	726,4	690,3	674,8	650,6	607,5	580,2
	Pa	kW	139,4	150,0	154,7	162,5	177,2	187,1	150,5	162,0	167,2	175,7	191,7	202,4
	qw	m³/h	111,09	105,62	103,28	99,59	93,05	88,90	124,95	118,74	116,07	111,90	104,49	99,79
	dpw	kPa	101,6	91,9	87,8	81,7	71,3	65,1	121,9	148,2	141,6	131,6	114,8	104,7
11°C	Pf	kW	665,2	632,5	618,4	596,4	557,2	532,3	748,3	711,1	695,2	670,2	625,8	597,7
	Pa	kW	141,5	152,1	156,9	164,8	179,6	189,6	152,7	164,3	169,5	178,1	194,2	205,1
	qw	m³/h	114,41	108,78	106,37	102,57	95,84	91,56	128,70	122,31	119,57	115,27	107,64	102,80
	dpw	kPa	107,8	97,4	93,2	86,6	75,6	69,0	129,3	116,8	111,6	103,7	90,5	82,5

- Tae** = Outdoor air temperature(°C);
Twout = Outlet water temperature (°C);
Pf = Cooling capacity (kW);
Pa = Compressors power input (kW) ;
qw = Water flow (m³/h);
dpw = Pressure drop (kPa).

Water flow and pressure drop on heat exchanger calculated with $\Delta T= 5\text{ }^{\circ}\text{C}$.

MULTIPIPE CHILLER RTMA

COOLING CAPACITY PERFORMANCE

RTMA

Twout			180						190					
			Tae						Tae					
			25°C	30°C	32°C	35°C	40°C	43°C	25°C	30°C	32°C	35°C	40°C	43°C
6°C	Pf	kW	679,9	644,3	629,1	605,6	564,3	538,5	720,8	685,4	670,2	646,4	604,1	577,3
	Pa	kW	153,2	165,7	171,2	180,1	196,6	207,5	163,3	175,9	181,6	190,8	208,2	219,8
	qw	m³/h	116,95	110,81	108,21	104,16	97,06	92,62	123,98	117,89	115,28	111,18	103,91	99,30
	dpw	kPa	103,6	93,0	88,7	82,2	71,4	65,0	45,6	41,2	39,4	36,7	32,0	29,3
7°C	Pf	kW	702,7	666,1	650,5	626,2	583,6	557,0	742,9	706,5	690,8	666,3	622,7	595,1
	Pa	kW	155,1	167,8	173,4	182,4	199,1	210,2	165,6	178,3	184,1	193,4	211,0	222,7
	qw	m³/h	120,87	114,56	111,88	107,71	100,38	95,80	127,78	121,52	118,82	114,60	107,11	102,36
	dpw	kPa	110,7	99,4	94,8	87,9	76,3	69,5	48,4	43,8	41,9	39,0	34,0	31,1
8°C	Pf	kW	726,0	688,3	672,3	647,3	603,4	575,9	765,5	728,0	711,9	686,6	641,8	613,3
	Pa	kW	157,1	169,9	175,6	184,7	201,7	213,0	168,0	180,8	186,6	196,0	213,8	225,7
	qw	m³/h	124,88	118,39	115,64	111,34	103,78	99,05	131,67	125,22	122,45	118,10	110,38	105,49
	dpw	kPa	118,1	106,2	101,3	93,9	81,6	74,3	51,4	46,5	44,5	41,4	36,1	33,0
9°C	Pf	kW	749,9	711,1	694,6	668,9	623,6	595,1	788,6	750,0	733,5	707,4	661,2	631,9
	Pa	kW	159,1	172,0	177,8	187,1	204,3	215,8	170,5	183,3	189,2	198,7	216,6	228,6
	qw	m³/h	128,98	122,32	119,48	115,05	107,25	102,36	135,65	129,01	126,15	121,68	113,73	108,69
	dpw	kPa	126,0	113,3	108,1	100,3	87,1	79,4	54,6	49,4	47,2	43,9	38,4	35,0
10°C	Pf	kW	774,3	734,5	717,5	690,9	644,2	614,8	812,3	772,5	755,5	728,7	681,1	650,9
	Pa	kW	161,2	174,3	180,1	189,5	207,0	218,6	173,0	186,0	191,8	201,4	219,5	231,7
	qw	m³/h	133,18	126,33	123,41	118,84	110,80	105,75	139,71	132,88	129,94	125,33	117,14	111,95
	dpw	kPa	134,4	120,9	115,3	107,0	93,0	84,7	57,9	185,6	177,5	165,1	144,3	131,7
11°C	Pf	kW	799,3	758,3	740,8	713,5	665,3	635,0	836,4	795,5	778,0	750,4	701,4	670,3
	Pa	kW	163,3	176,5	182,4	191,9	209,7	221,5	175,6	188,6	194,6	204,2	222,5	234,8
	qw	m³/h	137,49	130,44	127,42	122,72	114,43	109,22	143,87	136,83	133,81	129,07	120,63	115,29
	dpw	kPa	143,2	128,9	123,0	114,1	99,2	90,3	61,4	55,5	53,1	49,4	43,2	39,4

Tae = Outdoor air temperature(°C);
Twout = Outlet water temperature (°C);
Pf = Cooling capacity (kW);
Pa = Compressors power input (kW) ;
qw = Water flow (m3/h);
dpw = Pressure drop (kPa).

Water flow and pressure drop on heat exchanger calculated with $\Delta T= 5\text{ }^{\circ}\text{C}$.

COOLING CAPACITY PERFORMANCE

Twout			210					
			Tae					
			25°C	30°C	32°C	35°C	40°C	43°C
6°C	Pf	kW	793,0	754,0	737,3	711,1	664,6	635,1
	Pa	kW	180,7	194,6	200,9	211,2	230,4	243,2
	qw	m ³ /h	136,39	129,69	126,82	122,31	114,31	109,24
	dpw	kPa	54,1	49,0	46,8	43,5	38,0	34,7
7°C	Pf	kW	817,3	777,2	760,0	733,0	685,1	654,7
	Pa	kW	183,3	197,3	203,7	214,0	233,4	246,4
	qw	m ³ /h	140,57	133,68	130,72	126,08	117,83	112,61
	dpw	kPa	57,5	52,0	49,7	46,3	40,4	36,9
8°C	Pf	kW	842,2	800,9	783,2	755,4	706,0	674,7
	Pa	kW	185,9	200,1	206,5	216,9	236,5	249,7
	qw	m ³ /h	144,85	137,76	134,71	129,93	121,43	116,05
	dpw	kPa	61,1	55,2	52,8	49,1	42,9	39,2
9°C	Pf	kW	867,6	825,1	806,9	778,3	727,4	695,2
	Pa	kW	188,7	202,9	209,3	219,9	239,7	253,0
	qw	m ³ /h	149,23	141,92	138,78	133,86	125,11	119,57
	dpw	kPa	64,8	58,6	56,1	52,2	45,6	41,6
10°C	Pf	kW	893,6	849,9	831,1	801,6	749,3	716,0
	Pa	kW	191,5	205,8	212,3	222,9	242,9	256,4
	qw	m ³ /h	153,70	146,18	142,95	137,88	128,87	123,16
	dpw	kPa	68,8	62,2	59,5	55,3	48,3	44,1
11°C	Pf	kW	920,2	875,2	855,8	825,5	771,6	737,4
	Pa	kW	194,4	208,7	215,3	226,0	246,2	259,8
	qw	m ³ /h	158,27	150,53	147,20	141,99	132,71	126,83
	dpw	kPa	72,9	66,0	63,1	58,7	51,3	46,8

Tae = Outdoor air temperature(°C);
Twout = Outlet water temperature (°C);
Pf = Cooling capacity (kW);
Pa = Compressors power input (kW) ;
qw = Water flow (m³/h);
dpw = Pressure drop (kPa).
 Water flow and pressure drop on heat exchanger calculated with $\Delta T= 5\text{ }^{\circ}\text{C}$.

MULTIPIPE CHILLER RTMA

HEATING CAPACITY PERFORMANCE

RTMA

T.a.e. /R.U		105						115					
		Twout						Twout					
		30°C	35°C	40°C	45°C	55°C	65°C (1)	30°C	35°C	40°C	45°C	55°C	65°C (1)
-5°C / 90 %	Pt kW	309,0	296,2	283,8	272,3	254,1	245,6	348,7	334,1	319,8	306,4	284,7	273,7
	Pat kW	79,4	86,0	93,3	101,3	118,9	137,8	90,0	97,4	105,8	114,8	134,7	156,3
	qw m³/h	53,15	50,95	48,82	46,84	43,70	42,24	59,98	57,46	55,00	52,70	48,97	47,08
	dpw kPa	48,3	44,4	40,8	37,5	32,7	30,5	36,2	33,2	30,4	27,9	24,1	22,3
0°C / 90 %	Pt kW	370,0	355,0	340,2	325,8	301,0	284,6	417,6	400,6	383,5	366,9	337,9	318,0
	Pat kW	83,8	90,5	97,9	106,2	124,4	144,5	95,0	102,5	110,9	120,2	140,9	163,8
	qw m³/h	63,64	61,07	58,51	56,05	51,77	48,95	71,83	68,90	65,96	63,11	58,11	54,70
	dpw kPa	69,3	63,8	58,5	53,7	45,8	41,0	51,9	47,8	43,8	40,1	34,0	30,1
7°C / 90 %	Pt kW	466,4	448,4	430,0	411,8	377,8	350,4	526,4	506,0	485,0	464,1	424,7	392,5
	Pat kW	90,7	97,2	104,7	113,0	131,9	153,2	102,8	110,1	118,5	127,9	149,3	173,5
	qw m³/h	80,21	77,13	73,97	70,83	64,97	60,27	90,54	87,03	83,43	79,83	73,05	67,52
	dpw kPa	110,0	101,7	93,6	85,8	72,2	62,1	82,5	76,2	70,0	64,1	53,7	45,9
10°C / 90 %	Pt kW	512,8	493,5	473,6	453,6	415,5	383,4	578,8	556,9	534,2	511,3	467,4	429,8
	Pat kW	94,0	100,4	107,8	116,1	135,2	156,8	106,5	113,7	122,0	131,4	152,9	177,5
	qw m³/h	88,20	84,88	81,46	78,02	71,47	65,94	99,55	95,78	91,88	87,95	80,40	73,93
	dpw kPa	133,0	123,2	113,5	104,1	87,3	74,3	99,7	92,3	84,9	77,8	65,0	55,0
15°C / 90 %	Pt kW	595,6	574,0	551,6	528,7	483,8	443,6	672,1	647,7	622,2	596,1	544,6	497,9
	Pat kW	99,9	106,0	113,2	121,4	140,6	162,7	113,3	120,0	128,1	137,4	159,0	184,0
	qw m³/h	102,44	98,73	94,87	90,93	83,21	76,29	115,60	111,41	107,01	102,52	93,67	85,64
	dpw kPa	179,5	166,7	153,9	141,4	118,4	99,5	134,5	124,9	115,2	105,8	88,3	73,8

T.a.e /R.U. = Outdoor air temperature (°C)/Relative humidity (%)

Twout = Outlet water temperature (°C); hh

Pt = Heating capacity (kW);

Pa = Compressors power input (kW) ;

qw = Water flow (m³/h);

dpw = Pressure drop (kPa).

Water flow and pressure drop on heat exchanger calculated with $\Delta T = 5^\circ\text{C}$.

(1) Units equipped with the accessory High Performance temperature (HPT), with outlet water temperature up to 65°C.

HEATING CAPACITY PERFORMANCE

RTMA

Ta.e /R.U		120						130					
		Twout						Twout					
		30°C	35°C	40°C	45°C	55°C	65°C (1)	30°C	35°C	40°C	45°C	55°C	65°C (1)
-5°C / 90 %	Pt kW	363,2	347,6	332,4	318,2	295,7	284,8	398,8	386,1	373,6	361,6	341,0	328,0
	Pat kW	88,5	95,9	104,1	113,0	132,6	153,8	97,8	106,0	115,2	125,5	149,1	176,7
	qw m³/h	62,46	59,78	57,17	54,74	50,85	48,98	68,59	66,41	64,25	62,19	58,66	56,42
	dpw kPa	37,3	34,2	31,3	28,7	24,7	23,0	42,2	39,6	37,1	34,7	30,9	28,6
0°C / 90 %	Pt kW	435,7	417,5	399,3	381,8	351,2	330,8	470,7	455,7	440,4	425,4	397,6	376,0
	Pat kW	93,4	100,9	109,3	118,4	138,9	161,3	102,4	110,6	120,0	130,6	155,3	184,5
	qw m³/h	74,94	71,81	68,68	65,67	60,41	56,90	80,95	78,37	75,75	73,16	68,39	64,67
	dpw kPa	53,7	49,3	45,1	41,3	34,9	31,0	58,8	55,2	51,5	48,1	42,0	37,5
7°C / 90 %	Pt kW	550,5	528,7	506,3	484,1	442,5	408,8	585,0	566,5	547,1	527,5	489,1	454,8
	Pat kW	101,1	108,4	116,8	126,1	147,3	171,1	109,8	117,7	127,1	137,9	163,5	194,3
	qw m³/h	94,68	90,93	87,09	83,27	76,10	70,31	100,63	97,43	94,11	90,73	84,12	78,22
	dpw kPa	85,8	79,1	72,6	66,3	55,4	47,3	90,9	85,2	79,5	73,9	63,5	54,9
10°C / 90 %	Pt kW	605,8	582,4	558,3	533,9	487,4	447,9	640,8	620,6	599,4	577,6	534,2	494,1
	Pat kW	104,8	111,9	120,2	129,6	150,9	175,2	113,5	121,3	130,6	141,3	167,1	198,5
	qw m³/h	104,20	100,18	96,02	91,84	83,83	77,04	110,23	106,74	103,09	99,34	91,89	84,99
	dpw kPa	103,9	96,0	88,2	80,7	67,3	56,8	109,1	102,3	95,4	88,6	75,8	64,9
15°C / 90 %	Pt kW	704,6	678,5	651,2	623,4	568,8	519,6	741,9	718,6	694,0	668,5	616,6	566,6
	Pat kW	111,4	118,2	126,3	135,5	157,0	181,7	120,6	128,0	136,9	147,5	173,4	205,3
	qw m³/h	121,19	116,70	112,01	107,23	97,83	89,36	127,60	123,60	119,37	114,99	106,06	97,45
	dpw kPa	140,5	130,3	120,1	110,0	91,6	76,4	146,2	137,2	128,0	118,7	101,0	85,3

Ta.e. /R.U. = Outdoor air temperature (°C)/Relative humidity (%)

Twout = Outlet water temperature (°C);

Pt = Heating capacity (kW);

Pa = Compressors power input (kW) ;

qw = Water flow (m³/h);

dpw = Pressure drop (kPa).

Water flow and pressure drop on heat exchanger calculated with $\Delta T = 5^\circ\text{C}$.

(1) Units equipped with the accessory High Performance temperature (HPT), with outlet water temperature up to 65°C.

MULTIPIPE CHILLER RTMA

HEATING CAPACITY PERFORMANCE

RTMA

Ta.e. /R.U		150						170					
		Twout						Twout					
		30°C	35°C	40°C	45°C	55°C	65°C (1)	30°C	35°C	40°C	45°C	55°C	65°C (1)
-5°C / 90 %	Pt kW	448,3	438,1	427,8	417,7	399,6	386,2	512,2	500,3	488,2	476,2	454,0	436,5
	Pat kW	110,0	119,2	129,6	141,5	169,7	204,0	123,1	133,3	145,1	158,5	190,3	229,3
	qw m³/h	77,11	75,35	73,58	71,85	68,72	66,42	88,10	86,05	83,96	81,90	78,09	75,08
	dpw kPa	49,0	46,7	44,6	42,5	38,9	36,3	60,6	57,8	55,0	52,4	47,6	44,0
0°C / 90 %	Pt kW	523,6	511,3	498,5	485,6	460,6	438,9	597,6	583,2	568,2	552,9	522,8	495,9
	Pat kW	114,3	123,5	134,2	146,6	176,2	212,7	128,0	138,2	150,3	164,1	197,4	238,6
	qw m³/h	90,05	87,94	85,74	83,52	79,22	75,48	102,79	100,32	97,73	95,09	89,92	85,29
	dpw kPa	66,8	63,7	60,5	57,4	51,7	46,9	82,5	78,6	74,6	70,6	63,1	56,8
7°C / 90 %	Pt kW	644,5	628,6	611,7	594,1	558,2	523,6	734,8	716,2	696,4	675,7	633,2	591,6
	Pat kW	121,4	130,4	141,2	153,8	184,7	223,5	136,4	146,3	158,3	172,3	206,8	250,3
	qw m³/h	110,85	108,12	105,21	102,19	96,02	90,06	126,39	123,19	119,78	116,22	108,91	101,75
	dpw kPa	101,2	96,2	91,1	86,0	75,9	66,8	124,7	118,5	112,0	105,5	92,6	80,8
10°C / 90 %	Pt kW	704,3	686,6	667,6	647,7	606,6	565,8	802,7	781,9	759,7	736,4	687,9	639,4
	Pat kW	125,2	134,0	144,7	157,3	188,5	228,0	140,9	150,5	162,3	176,3	211,1	255,2
	qw m³/h	121,14	118,09	114,83	111,41	104,33	97,32	138,06	134,49	130,67	126,66	118,33	109,97
	dpw kPa	120,8	114,8	108,6	102,2	89,6	78,0	148,8	141,2	133,3	125,3	109,3	94,4
15°C / 90 %	Pt kW	814,2	793,0	770,3	746,2	695,7	644,0	927,2	902,5	876,0	847,9	788,8	727,9
	Pat kW	132,9	141,1	151,4	163,8	195,1	235,4	149,8	158,8	170,1	183,8	218,6	263,6
	qw m³/h	140,04	136,40	132,49	128,35	119,66	110,76	159,47	155,23	150,67	145,84	135,67	125,19
	dpw kPa	161,5	153,2	144,5	135,7	117,9	101,0	198,5	188,1	177,2	166,1	143,7	122,4

Ta.e. /R.U. = Outdoor air temperature (°C)/Relative humidity (%)

Twout = Outlet water temperature (°C);

Pt = Heating capacity (kW);

Pa = Compressors power input (kW) ;

qw = Water flow (m³/h);

dpw = Pressure drop (kPa).

Water flow and pressure drop on heat exchanger calculated with $\Delta T = 5^\circ\text{C}$.

(1) Units equipped with the accessory High Performance temperature (HPT), with outlet water temperature up to 65°C.

HEATING CAPACITY PERFORMANCE

RTMA

Ta.e. /R.U		180						190					
		Twout						Twout					
		30°C	35°C	40°C	45°C	55°C	65°C (1)	30°C	35°C	40°C	45°C	55°C	65°C (1)
-5°C / 90 %	Pt kW	527,1	514,9	502,8	491,0	470,2	455,5	543,3	530,8	518,1	505,6	482,6	464,7
	Pat kW	131,1	142,0	154,6	168,7	202,2	242,9	138,7	150,2	163,4	178,5	214,2	257,8
	qw m³/h	90,66	88,57	86,48	84,46	80,87	78,35	93,45	91,30	89,12	86,97	83,01	79,94
	dpw kPa	62,3	59,4	56,6	54,0	49,5	46,5	25,9	24,7	23,6	22,4	20,4	19,0
0°C / 90 %	Pt kW	616,1	601,5	586,4	571,2	542,2	517,5	634,1	619,0	603,3	587,3	556,0	528,2
	Pat kW	136,0	147,2	160,1	174,9	210,2	253,7	144,2	155,7	169,3	184,8	222,2	268,5
	qw m³/h	105,97	103,46	100,86	98,25	93,26	89,01	109,07	106,48	103,77	101,02	95,64	90,84
	dpw kPa	85,1	81,1	77,1	73,1	65,9	60,0	35,3	33,6	31,9	30,3	27,1	24,5
7°C / 90 %	Pt kW	759,1	740,2	720,2	699,4	657,3	617,1	780,0	760,5	739,7	718,1	673,7	630,3
	Pat kW	144,2	155,2	168,2	183,4	220,4	266,8	153,6	164,8	178,2	194,0	232,8	281,7
	qw m³/h	130,56	127,31	123,87	120,30	113,06	106,14	134,15	130,80	127,23	123,51	115,88	108,42
	dpw kPa	129,1	122,8	116,2	109,6	96,8	85,3	53,4	50,8	48,0	45,3	39,8	34,9
10°C / 90 %	Pt kW	829,8	808,7	786,2	762,7	714,3	666,7	852,1	830,4	807,1	782,7	732,0	681,3
	Pat kW	148,6	159,3	172,2	187,4	224,9	272,2	158,6	169,5	182,8	198,5	237,6	287,3
	qw m³/h	142,73	139,10	135,23	131,19	122,86	114,66	146,56	142,82	138,83	134,63	125,91	117,18
	dpw kPa	154,3	146,6	138,5	130,4	114,3	99,6	63,7	60,5	57,2	53,8	47,0	40,7
15°C / 90 %	Pt kW	959,7	934,5	907,5	879,1	819,3	758,5	984,5	958,6	930,9	901,5	839,4	775,6
	Pat kW	157,2	167,4	179,9	194,9	232,7	281,1	168,6	178,8	191,5	206,9	246,1	296,7
	qw m³/h	165,07	160,74	156,10	151,20	140,92	130,47	169,33	164,89	160,11	155,05	144,38	133,41
	dpw kPa	206,4	195,7	184,6	173,2	150,4	128,9	85,1	80,7	76,0	71,3	61,8	52,8

Ta.e. /R.U. = Outdoor air temperature (°C)/Relative humidity (%)

Twout = Outlet water temperature (°C);

Pt = Heating capacity (kW);

Pa = Compressors power input (kW) ;

qw = Water flow (m³/h);

dpw = Pressure drop (kPa).

Water flow and pressure drop on heat exchanger calculated with $\Delta T = 5^\circ\text{C}$.

(1) Units equipped with the accessory High Performance temperature (HPT), with outlet water temperature up to 65°C.

MULTIPIPE CHILLER RTMA

HEATING CAPACITY PERFORMANCE

RTMA

Ta.e. /R.U		210					
		Twout					
		30°C	35°C	40°C	45°C	55°C	65°C (1)
-5°C / 90 %	Pt kW	614,3	600,2	585,8	571,7	545,6	525,5
	Pat kW	151,5	164,1	178,5	194,9	233,9	281,6
	qw m³/h	105,66	103,23	100,76	98,33	93,85	90,38
	dpw kPa	32,5	31,0	29,6	28,1	25,6	23,8
0°C / 90 %	Pt kW	716,9	699,9	682,1	664,0	628,7	597,1
	Pat kW	157,5	170,1	184,9	201,8	242,7	293,2
	qw m³/h	124,13	121,44	118,60	115,67	109,92	104,79
	dpw kPa	44,8	42,9	40,9	38,9	35,2	32,0
7°C / 90 %	Pt kW	881,8	859,8	836,4	811,9	761,7	712,7
	Pat kW	167,7	180,0	194,7	211,9	254,3	307,7
	qw m³/h	151,68	147,89	143,85	139,65	131,01	122,58
	dpw kPa	67,0	63,7	60,2	56,8	50,0	43,7
10°C / 90 %	Pt kW	963,4	938,8	912,6	885,0	827,6	770,3
	Pat kW	173,3	185,1	199,6	216,8	259,5	313,8
	qw m³/h	165,70	161,48	156,96	152,22	142,35	132,49
	dpw kPa	79,9	75,9	71,7	67,4	59,0	51,1
15°C / 90 %	Pt kW	1113,1	1083,9	1052,4	1019,2	949,1	877,0
	Pat kW	184,2	195,2	209,2	226,0	268,8	324,1
	qw m³/h	191,45	186,43	181,02	175,30	163,24	150,84
	dpw kPa	106,7	101,2	95,4	89,4	77,6	66,2

Ta.e. /R.U. = Outdoor air temperature (°C)/Relative humidity (%)

Twout = Outlet water temperature (°C);

Pt = Heating capacity (kW);

Pa = Compressors power input (kW) ;

qw = Water flow (m³/h);

dpw = Pressure drop (kPa).

Water flow and pressure drop on heat exchanger calculated with $\Delta T = 5^\circ\text{C}$.

(1) Units equipped with the accessory High Performance temperature (HPT), with outlet water temperature up to 65°C.

RECOVERY CAPACITY PERFORMANCE



Twout		105							115					
		Twoutr							Twoutr					
		30°C	35°C	40°C	45°C	55°C	65°C (1)	30°C	35°C	40°C	45°C	55°C	65°C (1)	
6°C	Pf	kW	438,6	411,6	383,2	354,1	325,1	296,9	485,2	455,7	424,3	391,8	359,0	326,7
	Pa	kW	89,9	96,5	104,0	112,5	121,7	131,6	101,5	108,6	116,8	126,1	136,2	147,2
	qw	m³/h	75,45	70,80	65,91	60,91	55,92	51,07	83,46	78,38	72,98	67,40	61,75	56,19
	dpw	kPa	97,3	85,7	74,3	63,4	53,5	44,6	70,1	61,8	53,6	45,7	38,4	31,8
	Pr	kW	528,5	508,1	487,2	466,6	446,8	428,5	586,8	564,3	541,2	517,9	495,3	473,8
	qwr	m³/h	90,90	87,39	83,80	80,25	76,85	73,70	100,93	97,07	93,08	89,08	85,18	81,50
	dpwr	kPa	141,3	130,6	120,1	110,1	101,0	92,9	102,5	94,8	87,2	79,8	73,0	66,8
7°C	Pf	kW	455,0	427,5	398,5	368,7	338,9	309,8	502,7	472,7	440,8	407,7	374,0	340,8
	Pa	kW	90,9	97,5	105,0	113,5	122,7	132,7	102,8	109,8	118,0	127,2	137,4	148,3
	qw	m³/h	78,26	73,52	68,54	63,42	58,29	53,29	86,47	81,31	75,81	70,12	64,33	58,61
	dpw	kPa	104,7	92,4	80,3	68,8	58,1	48,6	75,2	66,5	57,8	49,5	41,6	34,6
	Pr	kW	545,9	524,9	503,5	482,2	461,7	442,5	605,5	582,5	558,7	534,9	511,4	489,1
	qwr	m³/h	93,89	90,29	86,60	82,94	79,41	76,11	104,15	100,19	96,10	92,00	87,96	84,13
	dpwr	kPa	150,8	139,4	128,3	117,6	107,8	99,1	109,1	101,0	92,9	85,2	77,8	71,2
8°C	Pf	kW	471,6	443,7	414,1	383,6	353,1	323,1	520,6	490,1	457,6	423,7	389,4	355,2
	Pa	kW	92,0	98,5	106,1	114,5	123,8	133,8	104,0	111,0	119,1	128,3	138,5	149,5
	qw	m³/h	81,12	76,31	71,22	65,99	60,73	55,58	89,54	84,30	78,70	72,88	66,97	61,10
	dpw	kPa	112,5	99,6	86,7	74,5	63,1	52,8	80,7	71,5	62,3	53,4	45,1	37,6
	Pr	kW	563,6	542,2	520,1	498,2	476,9	456,9	624,6	601,1	576,7	552,1	527,9	504,7
	qwr	m³/h	96,94	93,25	89,47	85,68	82,02	78,59	107,43	103,38	99,19	94,95	90,79	86,82
	dpwr	kPa	160,7	148,7	136,9	125,6	115,1	105,6	116,1	107,5	99,0	90,7	82,9	75,8
9°C	Pf	kW	488,7	460,2	430,0	398,9	367,6	336,8	538,8	507,8	474,7	440,2	405,1	370,0
	Pa	kW	93,1	99,6	107,1	115,6	124,8	134,9	105,3	112,2	120,3	129,5	139,7	150,7
	qw	m³/h	84,05	79,15	73,97	68,62	63,23	57,93	92,67	87,34	81,65	75,71	69,67	63,65
	dpw	kPa	120,8	107,1	93,6	80,5	68,4	57,4	86,4	76,8	67,1	57,7	48,8	40,8
	Pr	kW	581,7	559,8	537,1	514,5	492,4	471,7	644,0	620,0	595,0	569,7	544,7	520,7
	qwr	m³/h	100,06	96,28	92,39	88,49	84,70	81,12	110,77	106,64	102,34	97,98	93,69	89,57
	dpwr	kPa	171,2	158,5	146,0	133,9	122,7	112,5	123,5	114,4	105,4	96,6	88,3	80,7
10°C	Pf	kW	506,0	477,1	446,3	414,6	382,5	350,8	557,3	525,9	492,2	457,0	421,1	385,2
	Pa	kW	94,2	100,7	108,2	116,6	125,9	136,0	106,5	113,4	121,5	130,6	140,8	151,9
	qw	m³/h	87,03	82,06	76,77	71,31	65,79	60,34	95,86	90,45	84,66	78,61	72,43	66,26
	dpw	kPa	129,5	115,1	100,8	87,0	74,0	62,3	92,5	82,3	72,1	62,2	52,8	44,2
	Pr	kW	600,2	577,7	554,5	531,2	508,4	486,8	663,8	639,3	613,7	587,7	561,9	537,1
	qwr	m³/h	103,23	99,37	95,37	91,36	87,44	83,72	114,18	109,96	105,55	101,08	96,65	92,38
	dpwr	kPa	182,3	168,9	155,6	142,7	130,8	119,9	131,2	121,7	112,1	102,8	94,0	85,9
11°C	Pf	kW	523,7	494,3	463,0	430,6	397,7	365,2	576,2	544,3	510,0	474,2	437,5	400,7
	Pa	kW	95,3	101,7	109,2	117,7	127,0	137,0	107,9	114,7	122,7	131,8	142,0	153,1
	qw	m³/h	90,08	85,02	79,64	74,06	68,40	62,81	99,10	93,62	87,73	81,56	75,25	68,93
	dpw	kPa	138,8	123,6	108,5	93,8	80,0	67,5	98,8	88,2	77,4	66,9	57,0	47,8
	Pr	kW	619,0	596,0	572,2	548,2	524,7	502,2	684,0	658,9	632,7	606,0	579,5	553,8
	qwr	m³/h	106,47	102,52	98,42	94,29	90,24	86,38	117,65	113,34	108,82	104,23	99,67	95,25
	dpwr	kPa	193,9	179,7	165,7	152,0	139,3	127,6	139,3	129,3	119,2	109,3	100,0	91,3

Twout = Outlet water temperature (°C);
 Twoutr = Heating side heat exchanger leaving water temperature (°C);
 Pf = Cooling capacity (kW);
 Pr = Recovery mode heating capacity (kW);
 Pa = Compressors heating capacity (kW);
 qw = Water flow (m³/h);
 dpw = Pressure drop (kPa);
 qwr = Recovery heat exchanger water flow (m³/h);
 dpwr = Recovery heat exchanger pressure drop (kPa).

Water flow and pressure drop on heat exchanger calculated with ΔT= 5 °C

(1) Units equipped with the accessory High Performance temperature (HPT), with outlet water temperature up to 65°C.

MULTIPIPE CHILLER RTMA

RECOVERY CAPACITY PERFORMANCE

RTMA

Twout			120						130					
			Twoutr						Twoutr					
			30°C	35°C	40°C	45°C	55°C	65°C (1)	30°C	35°C	40°C	45°C	55°C	65°C (1)
6°C	Pf	kW	506,1	475,4	442,9	409,5	375,9	343,0	537,3	508,9	478,4	446,4	413,6	380,4
	Pa	kW	98,5	105,5	113,6	122,7	132,6	143,3	107,5	115,7	125,2	136,0	148,2	161,6
	qw	m³/h	87,05	81,77	76,18	70,43	64,65	58,99	92,41	87,52	82,28	76,79	71,14	65,44
	dpw	kPa	72,5	64,0	55,5	47,5	40,0	33,3	76,7	68,8	60,8	52,9	45,4	38,4
	Pr	kW	604,6	580,9	556,5	532,2	508,5	486,3	644,8	624,6	603,6	582,5	561,8	542,0
	qwr	m³/h	103,99	99,92	95,72	91,53	87,47	83,65	110,91	107,42	103,82	100,18	96,62	93,23
	dpwr	kPa	103,5	95,5	87,7	80,2	73,2	67,0	110,5	103,6	96,8	90,1	83,8	78,0
7°C	Pf	kW	524,5	493,3	460,2	426,0	391,6	357,7	556,4	527,4	496,3	463,5	429,7	395,5
	Pa	kW	99,7	106,6	114,7	132,9	133,8	144,5	108,6	116,8	126,3	137,1	149,3	162,8
	qw	m³/h	90,22	84,84	79,15	73,27	67,35	61,53	95,70	90,72	85,36	79,72	73,91	68,03
	dpw	kPa	77,9	68,9	60,0	51,4	43,4	36,2	82,2	73,9	65,4	57,1	49,1	41,6
	Pr	kW	624,2	599,9	574,9	558,9	525,3	502,2	665,1	644,2	622,5	600,6	579,0	558,3
	qwr	m³/h	107,36	103,19	98,88	96,13	90,36	86,38	114,39	110,80	107,07	103,30	99,59	96,03
	dpwr	kPa	110,3	101,9	93,6	88,4	78,1	71,4	117,5	110,2	102,9	95,8	89,1	82,8
8°C	Pf	kW	543,3	511,5	477,8	442,9	407,6	372,8	576,0	546,4	514,6	481,0	446,3	411,1
	Pa	kW	100,9	107,8	115,8	124,9	134,9	145,7	109,8	117,8	127,3	138,2	150,4	163,9
	qw	m³/h	93,45	87,98	82,18	76,18	70,11	64,13	99,08	93,99	88,51	82,73	76,76	70,70
	dpw	kPa	83,6	74,1	64,6	55,5	47,0	39,4	88,1	79,3	70,3	61,5	52,9	44,9
	Pr	kW	644,1	619,3	593,6	567,8	542,5	518,5	685,8	664,3	641,9	619,2	596,7	575,0
	qwr	m³/h	110,79	106,52	102,11	97,66	93,32	89,18	117,96	114,26	110,41	106,50	102,63	98,90
	dpwr	kPa	117,5	108,6	99,8	91,3	83,3	76,1	124,9	117,2	109,5	101,8	94,6	87,8
9°C	Pf	kW	562,4	530,2	495,8	460,2	424,1	388,3	596,1	565,9	533,3	498,9	463,3	427,0
	Pa	kW	102,1	109,0	117,0	126,0	136,0	146,9	111,0	119,0	128,4	139,3	151,5	165,1
	qw	m³/h	96,74	91,19	85,28	79,15	72,94	66,79	102,52	97,33	91,73	85,82	79,69	73,45
	dpw	kPa	89,6	79,6	69,6	60,0	50,9	42,7	94,4	85,1	75,6	66,1	57,0	48,4
	Pr	kW	664,5	639,1	612,8	586,2	560,1	535,2	707,0	684,9	661,8	638,2	614,8	592,2
	qwr	m³/h	114,29	109,93	105,40	100,83	96,34	92,05	121,61	117,80	113,82	109,78	105,75	101,85
	dpwr	kPa	125,0	115,6	106,3	97,3	88,8	81,1	132,8	124,6	116,3	108,2	100,4	93,1
10°C	Pf	kW	581,9	549,2	514,2	477,8	440,9	404,2	616,6	585,8	552,5	517,3	480,8	443,4
	Pa	kW	103,3	110,2	118,1	127,2	137,2	148,0	112,2	120,1	129,5	140,4	152,7	166,3
	qw	m³/h	100,09	94,45	88,44	82,19	75,83	69,52	106,05	100,76	95,04	88,98	82,69	76,27
	dpw	kPa	95,9	85,4	74,9	64,6	55,0	46,3	101,0	91,2	81,1	71,1	61,4	52,2
	Pr	kW	685,3	659,3	632,3	605,0	578,1	552,2	728,7	705,9	682,1	657,7	633,4	609,8
	qwr	m³/h	82,23	79,12	75,88	72,60	69,37	66,27	87,45	84,71	81,85	78,93	76,01	73,17
	dpwr	kPa	64,7	59,9	55,1	50,4	46,1	42,0	68,7	64,4	60,2	55,9	51,9	48,1
11°C	Pf	kW	601,8	568,5	532,9	495,9	458,1	420,5	637,6	606,2	572,2	536,2	498,7	460,3
	Pa	kW	104,6	111,4	119,3	128,3	138,3	149,2	113,4	121,3	130,7	141,5	153,8	167,5
	qw	m³/h	103,51	97,79	91,67	85,29	78,79	72,32	109,66	104,27	98,42	92,22	85,77	79,16
	dpw	kPa	102,5	91,5	80,4	69,6	59,4	50,1	108,0	97,6	87,0	76,4	66,1	56,3
	Pr	kW	706,4	679,9	652,3	624,2	596,4	569,7	751,0	727,5	702,9	677,7	652,5	627,8
	qwr	m³/h	121,50	116,94	112,19	107,36	102,59	97,98	129,17	125,13	120,90	116,57	112,23	107,98
	dpwr	kPa	141,3	130,9	120,4	110,3	100,7	91,9	149,8	140,6	131,2	122,0	113,1	104,7

Twout = Outlet water temperature (°C);
 Twoutr = Heating side heat exchanger leaving water temperature (°C);
 Pf = Cooling capacity (kW);
 Pr = Recovery mode heating capacity (kW);
 Pa = Compressors heating capacity (kW);
 qw = Water flow (m³/h);
 dpw = Pressure drop (kPa);
 qwr = Recovery heat exchanger water flow (m³/h);
 dpwr = Recovery heat exchanger pressure drop (kPa).

Water flow and pressure drop on heat exchanger calculated with $\Delta T = 5^\circ$

(1) Units equipped with the accessory High Performance temperature (HPT), with outlet water temperature up to 65°C.

RECOVERY CAPACITY PERFORMANCE

RTMA

Twout			150						170					
			Twoutr						Twoutr					
			30°C	35°C	40°C	45°C	55°C	65°C (1)	30°C	35°C	40°C	45°C	55°C	65°C (1)
6°C	Pf	kW	599,1	572,6	543,1	511,1	476,7	440,2	671,1	641,7	609,2	573,9	536,2	496,4
	Pa	kW	122,7	131,6	142,4	155,0	169,5	186,0	132,2	142,1	153,9	167,6	183,4	201,3
	qw	m³/h	103,04	98,48	93,42	87,90	81,99	75,72	115,43	110,38	104,78	98,71	92,22	85,38
	dpw	kPa	87,4	79,9	71,9	63,6	55,3	47,2	104,0	95,1	85,7	76,1	66,4	56,9
	Pr	kW	721,7	704,2	685,5	666,0	646,1	626,2	803,3	783,8	763,0	741,5	719,5	697,6
	qwr	m³/h	124,13	121,12	117,91	114,56	111,14	107,71	138,17	134,81	131,24	127,54	123,76	119,99
	dpwr	kPa	126,9	120,8	114,5	108,1	101,7	95,5	149,1	141,9	134,5	127,0	119,6	112,4
7°C	Pf	kW	619,3	592,2	562,1	529,2	493,9	456,4	693,8	663,8	630,4	594,2	555,4	514,5
	Pa	kW	123,9	132,8	143,5	156,1	170,6	187,2	133,5	143,3	155,0	168,8	184,6	202,6
	qw	m³/h	106,51	101,86	96,68	91,02	84,95	78,50	119,33	114,17	108,43	102,20	95,53	88,49
	dpw	kPa	93,4	85,4	77,0	68,2	59,4	50,7	111,2	101,8	91,8	81,5	71,2	61,1
	Pr	kW	743,1	725,0	705,6	685,3	664,5	643,6	827,3	807,0	785,5	763,0	740,0	717,0
	qwr	m³/h	127,82	124,70	121,36	117,87	114,30	110,70	142,29	138,81	135,10	131,24	127,29	123,33
	dpwr	kPa	134,5	128,0	121,3	114,4	107,6	100,9	158,1	150,4	142,5	134,5	126,5	118,7
8°C	Pf	kW	640,0	612,3	581,5	547,8	511,5	473,0	717,1	686,3	652,2	615,1	575,2	533,0
	Pa	kW	125,2	134,0	144,7	157,3	171,8	188,4	134,8	144,5	156,3	170,0	185,9	203,9
	qw	m³/h	110,08	105,32	100,02	94,22	87,99	81,36	123,33	118,05	112,18	105,79	98,93	91,68
	dpw	kPa	99,8	91,3	82,4	73,1	63,7	54,5	118,8	108,8	98,3	87,4	76,4	65,6
	Pr	kW	765,1	746,3	726,2	705,1	683,4	661,5	851,9	830,9	808,5	785,1	761,1	737,0
	qwr	m³/h	131,61	128,37	124,90	121,27	117,54	113,77	146,52	142,91	139,06	135,03	130,91	126,76
	dpwr	kPa	142,6	135,7	128,5	121,1	113,8	106,6	167,6	159,4	151,0	142,4	133,8	125,4
9°C	Pf	kW	661,2	633,0	601,5	566,9	529,7	490,1	740,9	709,5	674,6	636,5	595,5	552,1
	Pa	kW	126,5	135,2	145,9	158,4	173,0	189,7	136,2	145,8	157,5	171,3	187,2	205,3
	qw	m³/h	113,73	108,87	103,45	97,51	91,11	84,30	127,43	122,04	116,03	109,47	102,43	94,97
	dpw	kPa	106,5	97,6	88,1	78,3	68,3	58,5	126,8	116,3	105,1	93,6	81,9	70,4
	Pr	kW	787,7	768,2	747,3	725,4	702,7	679,8	877,1	855,3	832,1	807,7	782,7	757,4
	qwr	m³/h	135,49	132,13	128,54	124,76	120,87	116,93	150,86	147,12	143,12	138,93	134,63	130,28
	dpwr	kPa	151,2	143,8	136,0	128,2	120,3	112,6	177,7	169,0	159,9	150,7	141,5	132,5
10°C	Pf	kW	683,0	654,2	621,9	586,5	548,3	507,7	765,3	733,3	697,5	658,4	616,4	571,8
	Pa	kW	127,9	136,5	147,1	159,7	174,3	191,0	137,7	147,2	158,8	172,6	188,5	206,7
	qw	m³/h	117,47	112,52	106,97	100,88	94,31	87,32	131,64	126,12	119,97	113,25	106,02	98,35
	dpw	kPa	113,6	104,2	94,2	83,8	73,2	62,8	135,3	124,2	112,4	100,1	87,8	75,5
	Pr	kW	810,9	790,7	769,0	746,2	722,6	698,6	903,0	880,5	856,3	831,0	804,9	778,4
	qwr	m³/h	97,31	94,88	92,28	89,54	86,71	83,84	108,36	105,66	102,76	99,72	96,59	93,41
	dpwr	kPa	78,0	74,1	70,1	66,0	61,9	57,9	91,7	87,2	82,4	77,6	72,8	68,1
11°C	Pf	kW	705,3	675,9	642,9	606,6	567,5	525,7	790,4	757,6	721,0	681,0	637,8	592,0
	Pa	kW	129,4	137,9	148,4	160,9	175,5	192,3	139,2	148,6	160,2	173,9	189,8	208,1
	qw	m³/h	121,31	116,25	110,57	104,34	97,61	90,42	135,95	130,31	124,02	117,13	109,71	101,82
	dpw	kPa	121,2	111,3	100,7	89,6	78,4	67,3	144,3	132,6	120,1	107,1	94,0	80,9
	Pr	kW	834,7	813,8	791,3	767,6	743,0	718,0	929,6	906,2	881,2	854,9	827,7	800,0
	qwr	m³/h	143,57	139,97	136,10	132,02	127,80	123,50	159,89	155,87	151,57	147,04	142,36	137,61
	dpwr	kPa	169,7	161,3	152,5	143,5	134,5	125,6	199,6	189,7	179,3	168,8	158,2	147,8

Twout = Outlet water temperature (°C);
Twoutr = Heating side heat exchanger leaving water temperature (°C);
Pf = Cooling capacity (kW);
Pr = Recovery mode heating capacity (kW);
Pa = Compressors heating capacity (kW);
qw = Water flow (m³/h);
dpw = Pressure drop (kPa);
qwr = Recovery heat exchanger water flow (m³/h);
dpwr = Recovery heat exchanger pressure drop (kPa).

Water flow and pressure drop on heat exchanger calculated with $\Delta T = 5^\circ\text{C}$

(1) Units equipped with the accessory High Performance temperature (HPT), with outlet water temperature up to 65°C.

MULTIPIPE CHILLER RTMA

RECOVERY CAPACITY PERFORMANCE

RTMA

Twout			180						190					
			Twoutr						Twoutr					
			30°C	35°C	40°C	45°C	55°C	65°C (1)	30°C	35°C	40°C	45°C	55°C	65°C (1)
6°C	Pf	kW	708,5	677,0	642,2	604,6	564,5	522,4	753,7	720,6	683,8	643,6	600,4	554,7
	Pa	kW	142,5	153,3	166,2	181,1	198,3	217,6	152,2	163,2	176,4	192,0	209,9	230,3
	qw	m³/h	121,86	116,44	110,46	103,99	97,09	89,84	129,64	123,95	117,61	110,70	103,27	95,40
	dpw	kPa	112,5	102,7	92,4	81,9	71,4	61,1	49,9	45,6	41,0	36,4	31,6	27,0
	Pr	kW	850,9	830,3	808,4	785,7	762,8	740,0	905,9	883,8	860,2	835,6	810,3	785,0
	qwr	m³/h	146,36	142,80	139,04	135,14	131,20	127,27	155,82	152,02	147,96	143,72	139,38	135,01
	dpwr	kPa	162,2	154,5	146,4	138,3	130,4	122,7	72,0	68,6	64,9	61,3	57,6	54,1
	7°C	Pf	kW	732,6	700,4	664,8	626,2	585,0	541,5	779,0	745,2	707,5	666,3	622,0
Pa		kW	143,8	154,5	167,4	182,4	199,6	219,1	153,8	164,7	177,9	193,4	211,4	231,8
qw		m³/h	126,01	120,47	114,35	107,71	100,61	93,14	133,99	128,18	121,69	114,60	106,98	98,89
dpw		kPa	120,3	109,9	99,0	87,9	76,7	65,7	53,3	48,7	43,9	39,0	34,0	29,0
Pr		kW	876,4	855,0	832,2	808,6	784,6	760,6	932,8	909,9	885,4	859,7	833,3	806,8
qwr		m³/h	150,74	147,05	143,14	139,08	134,95	130,82	160,44	156,50	152,28	147,87	143,34	138,76
dpwr		kPa	172,1	163,8	155,2	146,5	137,9	129,6	76,4	72,7	68,8	64,9	61,0	57,1
8°C		Pf	kW	757,4	724,5	688,0	648,4	606,0	561,2	805,0	770,4	731,8	689,6	644,1
	Pa	kW	145,1	155,8	168,7	183,7	200,9	220,5	155,4	166,2	179,3	194,8	212,8	233,4
	qw	m³/h	130,27	124,61	118,34	111,52	104,23	96,53	138,45	132,51	125,88	118,61	110,79	102,48
	dpw	kPa	128,5	117,6	106,1	94,2	82,3	70,6	56,9	52,1	47,0	41,7	36,4	31,2
	Pr	kW	902,5	880,3	856,7	832,1	806,9	781,8	960,4	936,6	911,2	884,5	857,0	829,1
	qwr	m³/h	155,24	151,42	147,35	143,12	138,79	134,46	165,18	161,10	156,72	152,13	147,40	142,61
	dpwr	kPa	182,5	173,7	164,5	155,1	145,9	136,9	80,9	77,0	72,9	68,7	64,5	60,3
	9°C	Pf	kW	782,8	749,2	711,8	671,2	627,6	581,5	831,6	796,3	756,8	713,6	666,9
Pa		kW	146,6	157,2	170,0	185,0	202,3	222,0	157,1	167,8	180,8	196,3	214,3	234,9
qw		m³/h	134,64	128,86	122,43	115,44	107,95	100,02	143,03	136,96	130,17	122,73	114,71	106,16
dpw		kPa	137,3	125,8	113,5	100,9	88,3	75,8	60,7	55,6	50,3	44,7	39,0	33,4
Pr		kW	929,4	906,4	881,8	856,2	829,9	803,5	988,7	964,1	937,7	909,9	881,2	852,1
qwr		m³/h	159,85	155,89	151,67	147,26	142,74	138,20	170,05	165,82	161,28	156,50	151,57	146,57
dpwr		kPa	193,5	184,1	174,2	164,3	154,3	144,7	85,8	81,6	77,2	72,7	68,2	63,7
10°C		Pf	kW	808,9	774,5	736,2	694,5	649,8	602,4	858,8	822,8	782,4	738,1	690,3
	Pa	kW	148,1	158,6	171,4	186,4	203,7	223,4	158,9	169,4	182,4	197,9	215,9	236,5
	qw	m³/h	139,12	133,21	126,63	119,46	111,76	103,61	147,72	141,52	134,58	126,96	118,72	109,95
	dpw	kPa	146,6	134,4	121,5	108,1	94,6	81,3	64,7	59,4	53,7	47,8	41,8	35,9
	Pr	kW	956,9	933,1	907,6	880,9	853,5	825,8	1017,7	992,2	964,8	936,0	906,1	875,8
	qwr	m³/h	164,59	160,49	156,11	151,52	146,80	142,04	175,04	170,66	165,95	160,99	155,86	150,63
	dpwr	kPa	205,2	195,1	184,6	173,9	163,2	152,8	90,9	86,4	81,7	76,9	72,1	67,3
	11°C	Pf	kW	835,6	800,4	761,3	718,5	672,6	623,8	886,7	849,9	808,7	763,3	714,2
Pa		kW	149,6	160,1	172,8	187,8	205,1	224,9	160,8	171,2	184,1	199,5	217,5	238,1
qw		m³/h	143,72	137,67	130,94	123,59	115,68	107,30	152,52	146,19	139,09	131,29	122,85	113,84
dpw		kPa	156,4	143,6	129,9	115,7	101,4	87,2	69,0	63,4	57,4	51,1	44,8	38,4
Pr		kW	985,2	960,5	934,0	906,3	877,7	848,7	1047,5	1021,1	992,7	962,8	931,7	900,0
qwr		m³/h	169,46	165,21	160,66	155,88	150,96	145,98	180,17	175,63	170,75	165,60	160,26	154,80
dpwr		kPa	217,5	206,7	195,5	184,1	172,6	161,4	96,3	91,5	86,5	81,4	76,2	71,1

- Twout** = Outlet water temperature (°C);
- Twoutr** = Heating side heat exchanger leaving water temperature (°C);
- Pf** = Cooling capacity (kW);
- Pr** = Recovery mode heating capacity (kW);
- Pa** = Compressors heating capacity (kW);
- qw** = Water flow (m³/h);
- dpw** = Pressure drop (kPa);
- qwr** = Recovery heat exchanger water flow (m³/h);
- dpwr** = Recovery heat exchanger pressure drop (kPa).

Water flow and pressure drop on heat exchanger calculated with $\Delta T = 5^\circ\text{C}$

(1) Units equipped with the accessory High Performance temperature (HPT), with outlet water temperature up to 65°C.

RECOVERY CAPACITY PERFORMANCE

RTMA

Twout			210					
			Twoutr					
			30°C	35°C	40°C	45°C	55°C	65°C (1)
6°C	Pf	kW	830,1	793,5	752,8	708,4	660,6	610,1
	Pa	kW	168,8	181,0	195,7	212,9	232,8	255,4
	qw	m ³ /h	142,77	136,48	129,48	121,84	113,63	104,93
	dpw	kPa	59,3	54,2	48,8	43,2	37,6	32,0
	Pr	kW	998,9	974,5	948,5	921,3	893,5	865,5
	qwr	m ³ /h	171,81	167,61	163,14	158,46	153,68	148,86
	dpwr	kPa	85,9	81,8	77,5	73,1	68,7	64,5
7°C	Pf	kW	858,0	820,6	778,9	733,0	684,4	632,4
	Pa	kW	170,5	182,6	197,3	214,0	234,4	257,1
	qw	m ³ /h	147,57	141,14	133,98	126,08	117,72	108,78
	dpw	kPa	63,4	58,0	52,2	46,3	40,3	34,4
	Pr	kW	1028,5	1003,2	976,2	947,0	918,8	889,5
	qwr	m ³ /h	176,90	172,55	167,91	162,88	158,04	153,00
	dpwr	kPa	91,1	86,7	82,1	77,2	72,7	68,1
8°C	Pf	kW	886,5	848,4	805,8	759,1	708,8	655,4
	Pa	kW	172,4	184,3	198,9	216,1	236,1	258,8
	qw	m ³ /h	152,48	145,92	138,59	130,57	121,92	112,73
	dpw	kPa	67,7	62,0	55,9	49,6	43,3	37,0
	Pr	kW	1058,9	1032,7	1004,6	975,2	944,9	914,2
	qwr	m ³ /h	182,13	177,62	172,80	167,74	162,52	157,24
	dpwr	kPa	96,5	91,8	86,9	81,9	76,9	72,0
9°C	Pf	kW	915,8	876,9	833,3	785,5	733,9	679,0
	Pa	kW	174,2	186,1	200,6	217,8	237,7	260,6
	qw	m ³ /h	157,52	150,82	143,32	135,10	126,23	116,79
	dpw	kPa	72,2	66,2	59,8	53,1	46,4	39,7
	Pr	kW	1090,1	1063,0	1033,8	1003,2	971,6	939,6
	qwr	m ³ /h	187,49	182,83	177,82	172,56	167,12	161,60
	dpwr	kPa	102,3	97,3	92,0	86,7	81,3	76,0
10°C	Pf	kW	945,9	906,1	861,5	812,6	759,7	703,3
	Pa	kW	176,2	187,9	202,3	219,5	239,4	262,3
	qw	m ³ /h	162,69	155,85	148,18	139,76	130,66	120,96
	dpw	kPa	77,0	70,7	63,9	56,9	49,7	42,6
	Pr	kW	1122,1	1094,0	1063,8	1032,0	999,1	965,6
	qwr	m ³ /h	193,00	188,17	182,98	177,51	171,85	166,08
	dpwr	kPa	108,4	103,1	97,4	91,7	86,0	80,3
11°C	Pf	kW	976,7	936,0	890,4	840,3	786,1	728,2
	Pa	kW	178,3	189,8	204,1	221,2	241,2	264,1
	qw	m ³ /h	167,99	161,00	153,16	144,54	135,21	125,25
	dpw	kPa	82,1	75,4	68,3	60,8	53,2	45,7
	Pr	kW	1155,0	1125,9	1094,6	1061,6	1027,3	992,4
	qwr	m ³ /h	198,66	193,65	188,27	182,59	176,70	170,68
	dpwr	kPa	114,9	109,2	103,2	97,0	90,9	84,8

Twout = Outlet water temperature (°C);
Twoutr = Heating side heat exchanger leaving water temperature (°C);
Pf = Cooling capacity (kW);
Pr = Recovery mode heating capacity (kW);
Pa = Compressors heating capacity (kW);
qw = Water flow (m³/h);
dpw = Pressure drop (kPa);
qwr = Recovery heat exchanger water flow (m³/h);
dpwr = Recovery heat exchanger pressure drop (kPa).

Water flow and pressure drop on heat exchanger calculated with $\Delta T = 5^\circ\text{C}$

(1) Units equipped with the accessory High Performance temperature (HPT), with outlet water temperature up to 65°C.

MULTIPIPE CHILLER RTMA

COOLING CAPACITY PERFORMANCE

RTMA LN

Twout			105						115					
			Tae						Tae					
			25°C	30°C	32°C	35°C	40°C	43°C	25°C	30°C	32°C	35°C	40°C	43°C
6°C	Pf	kW	406,2	374,5	361,5	341,8	321,7	302,3	443,4	413,4	401,1	382,2	362,7	343,7
	Pa	kW	98,2	106,2	109,7	115,2	121,3	127,5	111,3	119,6	123,2	128,9	135,4	141,8
	qw	m ³ /h	69,86	64,41	62,17	58,79	55,33	52,00	76,26	71,11	68,98	65,74	62,39	59,11
	dpw	kPa	85,5	73,9	69,3	62,7	56,2	50,3	59,8	52,7	49,9	45,8	41,6	37,8
7°C	Pf	kW	421,7	389,2	375,8	355,7	335,0	315,1	457,7	427,1	414,5	395,2	375,3	355,8
	Pa	kW	99,7	107,9	111,4	116,9	123,2	129,3	113,1	121,4	125,0	130,8	137,3	143,8
	qw	m ³ /h	72,52	66,94	64,64	61,18	57,63	54,19	78,73	73,47	71,29	67,98	64,55	61,19
	dpw	kPa	91,6	79,3	74,5	67,4	60,6	54,2	63,4	55,9	53,0	48,6	44,3	40,3
8°C	Pf	kW	437,5	404,2	390,6	369,9	348,7	328,2	472,3	441,1	428,2	408,5	388,1	368,1
	Pa	kW	101,3	109,5	113,1	118,7	125,0	131,2	114,8	123,2	126,8	132,6	139,2	145,7
	qw	m ³ /h	75,25	69,53	67,18	63,62	59,98	56,45	81,24	75,87	73,65	70,26	66,76	63,32
	dpw	kPa	98,0	85,0	79,9	72,4	65,1	58,4	67,1	59,3	56,2	51,7	47,1	42,8
9°C	Pf	kW	453,7	419,7	405,7	384,5	362,8	341,7	487,2	455,3	442,1	422,0	401,2	380,7
	Pa	kW	103,0	111,2	114,8	120,5	126,8	133,2	116,6	125,0	128,7	134,5	141,1	147,7
	qw	m ³ /h	78,04	72,19	69,78	66,13	62,39	58,77	83,79	78,31	76,04	72,58	69,00	65,48
	dpw	kPa	104,7	91,0	85,6	77,7	70,0	62,9	71,0	62,9	59,6	54,8	50,1	45,6
10°C	Pf	kW	470,3	435,5	421,2	399,4	377,1	355,5	502,3	469,7	456,3	435,7	414,4	393,5
	Pa	kW	104,6	112,9	116,6	122,3	128,7	135,1	118,4	126,9	130,6	136,4	143,0	149,7
	qw	m ³ /h	80,90	74,90	72,44	68,70	64,87	61,14	86,39	80,80	78,48	74,95	71,28	67,68
	dpw	kPa	112,1	97,6	91,9	83,5	75,3	67,7	75,3	66,7	63,3	58,3	53,2	48,5
11°C	Pf	kW	487,3	451,7	437,0	414,7	391,9	369,6	517,6	484,4	470,7	449,7	427,9	406,5
	Pa	kW	106,3	114,7	118,3	124,1	130,6	137,0	120,3	128,7	132,4	138,3	145,0	151,7
	qw	m ³ /h	83,82	77,68	75,16	71,33	67,40	63,57	89,03	83,32	80,96	77,35	73,60	69,92
	dpw	kPa	119,8	104,5	98,5	89,6	80,9	72,8	79,7	70,7	67,2	61,9	56,6	51,6

Tae = Outdoor air temperature(°C);
Twout = Outlet water temperature (°C);
Pf = Cooling capacity (kW);
Pa = Compressors power input (kW) ;
qw = Water flow (m³/h);
dpw = Pressure drop (kPa).

Water flow and pressure drop on heat exchanger calculated with $\Delta T= 5^\circ$

COOLING CAPACITY PERFORMANCE

RTMA LN

Twout			120						130					
			Tae						Tae					
			25°C	30°C	32°C	35°C	40°C	43°C	25°C	30°C	32°C	35°C	40°C	43°C
6°C	Pf	kW	461,7	431,4	418,8	399,6	379,6	360,0	501,3	468,2	454,5	433,5	411,8	390,4
	Pa	kW	108,4	116,4	119,9	125,4	131,7	138,0	118,5	128,3	132,6	139,5	147,2	155,0
	qw	m ³ /h	79,41	74,20	72,03	68,73	65,29	61,92	86,23	80,53	78,17	74,57	70,84	67,16
	dpw	kPa	61,6	54,5	51,7	47,5	43,3	39,4	68,2	60,3	57,2	52,5	47,9	43,5
7°C	Pf	kW	476,7	445,8	432,9	413,3	392,8	372,7	519,1	485,1	471,1	449,5	427,2	405,1
	Pa	kW	110,2	118,1	121,7	127,3	133,6	139,9	120,1	130,1	134,5	141,4	149,3	157,2
	qw	m ³ /h	81,99	76,67	74,46	71,08	67,57	64,11	89,29	83,45	81,02	77,32	73,47	69,67
	dpw	kPa	65,3	57,9	54,9	50,5	46,1	42,0	72,7	64,4	61,1	56,1	51,2	46,5
8°C	Pf	kW	492,0	460,4	447,3	427,2	406,3	385,8	537,3	502,5	488,0	465,8	442,8	420,1
	Pa	kW	111,9	120,0	123,5	129,1	135,5	141,9	121,8	131,9	136,3	143,4	151,3	159,3
	qw	m ³ /h	84,63	79,20	76,94	73,48	69,89	66,35	92,42	86,43	83,93	80,13	76,17	72,25
	dpw	kPa	69,2	61,4	58,3	53,7	49,1	44,7	77,5	68,6	65,1	59,9	54,7	49,7
9°C	Pf	kW	507,6	475,4	461,9	441,4	420,1	399,0	556,0	520,2	505,3	482,6	458,9	435,4
	Pa	kW	113,7	121,8	125,4	131,0	137,4	143,9	123,6	133,7	138,2	145,3	153,4	161,5
	qw	m ³ /h	87,31	81,76	79,45	75,92	72,25	68,63	95,63	89,47	86,92	83,00	78,93	74,89
	dpw	kPa	73,3	65,1	61,9	57,0	52,1	47,5	82,4	73,1	69,4	63,9	58,4	53,1
10°C	Pf	kW	523,5	490,5	476,8	455,9	434,0	412,5	575,1	538,3	523,1	499,7	475,3	451,1
	Pa	kW	115,5	123,6	127,2	132,9	139,4	145,9	125,3	135,6	140,1	147,3	155,5	163,7
	qw	m ³ /h	90,03	84,37	82,01	78,41	74,65	70,95	98,91	92,60	89,97	85,94	81,75	77,59
	dpw	kPa	77,7	69,1	65,7	60,6	55,5	50,6	87,9	78,0	74,1	68,2	62,4	56,8
11°C	Pf	kW	539,6	506,0	492,0	470,6	448,3	426,3	594,6	556,9	541,2	517,2	492,1	467,2
	Pa	kW	117,4	125,5	129,1	134,9	141,3	147,9	127,1	137,5	142,1	149,3	157,6	165,9
	qw	m ³ /h	92,81	87,03	84,62	80,94	77,10	73,32	102,26	95,79	93,09	88,95	84,64	80,36
	dpw	kPa	82,3	73,3	69,7	64,3	59,0	53,9	93,6	83,2	79,0	72,8	66,6	60,6

- Tae** = Outdoor air temperature(°C);
- Twout** = Outlet water temperature (°C);
- Pf** = Cooling capacity (kW);
- Pa** = Compressors power input (kW) ;
- qw** = Water flow (m³/h);
- dpw** = Pressure drop (kPa).

Water flow and pressure drop on heat exchanger calculated with ΔT= 5 °C.

MULTIPIPE CHILLER RTMA

COOLING CAPACITY PERFORMANCE

RTMA LN

Twout			150						170					
			Tae						Tae					
			25°C	30°C	32°C	35°C	40°C	43°C	25°C	30°C	32°C	35°C	40°C	43°C
6°C	Pf	kW	562,0	532,6	520,1	500,5	479,5	458,2	631,5	598,1	583,9	561,7	538,0	513,9
	Pa	kW	135,2	146,2	151,1	159,0	168,1	177,5	146,1	158,0	163,3	172,0	181,9	192,1
	qw	m ³ /h	96,67	91,61	89,45	86,08	82,48	78,81	108,61	102,88	100,43	96,61	92,54	88,38
	dpw	kPa	78,4	71,2	68,2	63,6	58,9	54,3	93,8	85,1	81,5	76,0	70,3	64,8
7°C	Pf	kW	579,4	549,1	536,2	516,0	494,4	472,4	651,1	616,8	602,1	579,2	554,8	529,9
	Pa	kW	137,1	148,1	153,1	161,1	170,3	179,8	148,1	160,1	165,5	174,2	184,3	194,6
	qw	m ³ /h	99,66	94,45	92,23	88,75	85,04	81,25	111,99	106,09	103,57	99,63	95,43	91,15
	dpw	kPa	82,9	75,3	72,1	67,3	62,3	57,4	99,3	90,0	86,2	80,4	74,4	68,5
8°C	Pf	kW	597,1	566,0	552,7	531,9	509,6	486,9	671,2	635,8	620,8	597,2	572,0	546,3
	Pa	kW	139,0	150,2	155,2	163,3	172,6	182,2	150,2	162,3	167,7	176,6	186,7	197,1
	qw	m ³ /h	102,71	97,35	95,06	91,48	87,65	83,75	115,45	109,36	106,77	102,72	98,38	93,97
	dpw	kPa	87,6	79,6	76,2	71,1	65,9	60,7	105,0	95,2	91,2	85,0	78,7	72,5
9°C	Pf	kW	615,3	583,2	569,5	548,1	525,1	501,7	691,7	655,3	639,8	615,5	589,6	563,1
	Pa	kW	141,0	152,2	157,3	165,5	174,9	184,6	152,3	164,5	170,0	178,9	189,2	199,7
	qw	m ³ /h	105,83	100,31	97,95	94,27	90,32	86,30	118,98	112,72	110,04	105,87	101,40	96,85
	dpw	kPa	92,6	84,0	80,5	75,2	69,6	64,1	110,9	100,6	96,4	89,9	83,2	76,6
10°C	Pf	kW	633,8	600,8	586,7	564,6	541,0	516,9	712,7	675,2	659,2	634,2	607,5	580,2
	Pa	kW	143,1	154,3	159,4	167,7	177,2	187,1	154,5	166,8	172,3	181,3	191,7	202,4
	qw	m ³ /h	109,02	103,34	100,91	97,11	93,05	88,90	122,59	116,14	113,39	109,09	104,49	99,79
	dpw	kPa	97,9	88,9	85,2	79,5	73,6	67,8	117,4	106,5	102,0	95,2	88,1	81,1
11°C	Pf	kW	652,8	618,8	604,2	581,5	557,2	532,3	734,2	695,6	679,1	653,4	625,8	597,7
	Pa	kW	145,2	156,5	161,7	170,0	179,6	189,6	156,7	169,1	174,7	183,8	194,2	205,1
	qw	m ³ /h	112,28	106,43	103,93	100,02	95,84	91,56	126,28	119,64	116,81	112,38	107,64	102,80
	dpw	kPa	103,6	94,1	90,1	84,1	77,9	71,7	124,2	112,7	107,9	100,7	93,2	85,8

Tae = Outdoor air temperature(°C);
Twout = Outlet water temperature (°C);
Pf = Cooling capacity (kW);
Pa = Compressors power input (kW) ;
qw = Water flow (m³/h);
dpw = Pressure drop (kPa).

Water flow and pressure drop on heat exchanger calculated with $\Delta T = 5$ °C.

COOLING CAPACITY PERFORMANCE
RTMA LN

Twout			180						190					
			Tae						Tae					
			25°C	30°C	32°C	35°C	40°C	43°C	25°C	30°C	32°C	35°C	40°C	43°C
6°C	Pf	kW	666,3	629,5	613,9	589,8	564,3	538,5	707,3	670,6	654,9	630,3	604,1	577,3
	Pa	kW	157,6	170,8	176,6	185,9	196,6	207,5	167,7	181,1	187,2	197,0	208,2	219,8
	qw	m ³ /h	114,26	107,94	105,27	101,14	96,77	92,34	121,30	114,99	112,30	108,09	103,59	99,00
	dpw	kPa	101,4	91,6	87,5	81,4	75,2	69,1	44,7	40,6	38,9	36,4	33,7	31,0
7°C	Pf	kW	688,7	650,8	634,8	609,9	583,6	557,0	729,1	691,2	675,1	649,8	622,7	595,1
	Pa	kW	159,5	172,9	178,8	188,3	199,1	210,2	170,0	183,6	189,7	199,6	211,0	222,7
	qw	m ³ /h	118,46	111,94	109,19	104,91	100,38	95,80	125,40	118,89	116,11	111,76	107,11	102,36
	dpw	kPa	107,8	97,3	93,1	86,6	80,0	73,6	47,3	43,0	41,2	38,4	35,6	32,8
8°C	Pf	kW	711,6	672,7	656,2	630,5	603,4	575,9	751,3	712,3	695,7	669,6	641,8	613,3
	Pa	kW	161,6	175,1	181,1	190,7	201,7	213,0	172,4	186,1	192,3	202,3	213,8	225,7
	qw	m ³ /h	122,40	115,70	112,86	108,45	103,78	99,05	129,22	122,52	119,65	115,18	110,38	105,49
	dpw	kPa	114,4	103,4	98,9	92,0	85,0	78,2	50,0	45,4	43,5	40,6	37,6	34,7
9°C	Pf	kW	735,1	695,0	678,0	651,6	623,6	595,1	774,0	733,9	716,7	689,9	661,2	631,9
	Pa	kW	163,6	177,3	183,4	193,2	204,3	215,8	174,9	188,7	194,9	205,0	216,6	228,6
	qw	m ³ /h	126,44	119,54	116,62	112,07	107,25	102,36	133,12	126,23	123,28	118,67	113,73	108,69
	dpw	kPa	121,4	109,8	105,0	97,8	90,3	83,0	52,8	47,9	46,0	42,9	39,7	36,6
10°C	Pf	kW	759,1	717,9	700,4	673,1	644,2	614,8	797,2	755,9	738,3	710,6	681,1	650,9
	Pa	kW	165,8	179,6	185,8	195,7	207,0	218,6	177,5	191,3	197,6	207,8	219,5	231,7
	qw	m ³ /h	130,57	123,47	120,46	115,78	110,80	105,75	137,12	130,02	126,98	122,23	117,14	111,95
	dpw	kPa	129,1	116,7	111,6	104,0	96,1	88,3	55,8	50,7	48,6	45,4	42,0	38,7
11°C	Pf	kW	783,7	741,3	723,2	695,1	665,3	635,0	820,9	778,4	760,2	731,8	701,4	670,3
	Pa	kW	167,9	181,9	188,2	198,2	209,7	221,5	180,1	194,1	200,4	210,6	222,5	234,8
	qw	m ³ /h	134,80	127,50	124,39	119,57	114,43	109,22	141,20	133,89	130,76	125,87	120,63	115,29
	dpw	kPa	137,1	124,0	118,6	110,5	102,1	93,9	59,0	53,6	51,4	48,0	44,5	41,0

Tae = Outdoor air temperature
Twout = Outlet water temperature (°C);
Pf = Cooling capacity (kW);
Pa = Compressors power input (kW) ;
qw = Water flow (m³/h);
dpw = Pressure drop (kPa).
 Water flow and pressure drop on heat exchanger calculated with $\Delta T = 5\text{ }^{\circ}\text{C}$.

MULTIPIPE CHILLER RTMA

COOLING CAPACITY PERFORMANCE

RTMA LN

Twout			210					
			Tae					
			25°C	30°C	32°C	35°C	40°C	43°C
6°C	Pf	kW	778,1	737,7	720,4	693,4	664,6	635,1
	Pa	kW	185,5	200,4	207,1	217,9	230,4	243,2
	qw	m ³ /h	133,84	126,89	123,92	119,27	114,31	109,24
	dpw	kPa	53,1	48,3	46,2	43,2	40,0	36,9
7°C	Pf	kW	802,0	760,4	742,6	714,8	685,1	654,7
	Pa	kW	188,1	203,1	209,9	220,8	233,4	246,4
	qw	m ³ /h	137,95	130,79	127,73	122,95	117,83	112,61
	dpw	kPa	56,1	51,0	48,9	45,6	42,3	39,0
8°C	Pf	kW	826,5	783,6	765,3	736,7	706,0	674,7
	Pa	kW	190,8	205,9	212,7	223,8	236,5	249,7
	qw	m ³ /h	142,15	134,78	131,63	126,71	121,43	116,05
	dpw	kPa	59,3	53,9	51,7	48,2	44,7	41,2
9°C	Pf	kW	851,5	807,3	788,5	759,0	727,4	695,2
	Pa	kW	193,6	208,8	215,7	226,8	239,7	253,0
	qw	m ³ /h	146,45	138,86	135,62	130,54	125,11	119,57
	dpw	kPa	62,7	56,9	54,6	50,9	47,2	43,5
10°C	Pf	kW	877,0	831,6	812,2	781,8	749,3	716,0
	Pa	kW	196,4	211,7	218,7	229,9	242,9	256,4
	qw	m ³ /h	150,84	143,03	139,69	134,47	128,87	123,16
	dpw	kPa	66,3	60,2	57,7	53,9	49,9	46,0
11°C	Pf	kW	903,1	856,3	836,3	805,1	771,6	737,4
	Pa	kW	199,3	214,7	221,7	233,1	246,2	259,8
	qw	m ³ /h	155,33	147,29	143,85	138,47	132,71	126,83
	dpw	kPa	70,1	63,7	61,0	57,0	52,8	48,6

Tae = Outdoor air temperature
Twout = Outlet water temperature (°C);
Pf = Cooling capacity (kW);
Pa = Compressors power input (kW) ;
qw = Water flow (m³/h);
dpw = Pressure drop (kPa).

Water flow and pressure drop on heat exchanger calculated with $\Delta T = 5$ °C.

HEATING CAPACITY PERFORMANCE

RTMA LN

Ta /R.U		105						115					
		Twout						Twout					
		30°C	35°C	40°C	45°C	55°C	65°C (1)	30°C	35°C	40°C	45°C	55°C	65°C (1)
-5°C / 90 %	Pt kW	312,9	300,0	287,4	275,7	257,0	248,0	353,1	338,3	323,8	310,2	288,0	276,5
	Pat kW	79,6	86,3	93,6	101,7	119,2	138,3	90,3	97,8	106,1	115,2	135,2	156,9
	qw m³/h	53,82	51,59	49,43	47,42	44,21	42,65	60,74	58,19	55,70	53,36	49,54	47,55
	dpw kPa	52,1	47,9	43,9	40,4	35,1	32,7	38,8	35,6	32,6	29,9	25,8	23,8
0°C / 90 %	Pt kW	374,4	359,3	344,3	329,8	304,5	287,5	422,6	405,4	388,1	371,4	341,8	321,3
	Pat kW	84,1	90,8	98,3	106,5	124,8	145,0	95,4	102,8	111,3	120,6	141,4	164,3
	qw m³/h	64,40	61,80	59,21	56,72	52,37	49,46	72,69	69,73	66,76	63,88	58,79	55,27
	dpw kPa	74,5	68,7	63,0	57,8	49,3	44,0	55,5	51,1	46,8	42,9	36,3	32,1
7°C / 90 %	Pt kW	471,5	453,4	434,9	416,4	381,9	354,0	532,2	511,6	490,5	469,3	429,4	396,6
	Pat kW	91,0	97,5	105,0	113,3	132,3	153,6	103,2	110,5	118,9	128,3	149,7	173,9
	qw m³/h	81,10	77,99	74,80	71,63	65,69	60,89	91,54	88,00	84,36	80,73	73,86	68,22
	dpw kPa	118,2	109,3	100,6	92,2	77,6	66,7	88,1	81,4	74,8	68,5	57,4	48,9
10°C / 90 %	Pt kW	518,3	498,8	478,7	458,6	420,0	387,3	584,9	562,9	540,0	516,9	472,5	434,3
	Pat kW	94,4	100,7	108,1	116,4	135,5	157,3	107,0	114,1	122,4	131,8	153,3	178,0
	qw m³/h	89,14	85,80	82,34	78,87	72,24	66,61	100,61	96,81	92,88	88,91	81,27	74,69
	dpw kPa	142,8	132,3	121,9	111,8	93,8	79,8	106,4	98,5	90,7	83,1	69,4	58,6
15°C / 90 %	Pt kW	601,6	579,9	557,2	534,1	488,8	448,0	678,9	654,3	628,6	602,2	550,2	502,9
	Pat kW	100,3	106,4	113,6	121,8	140,9	163,1	113,8	120,5	128,6	137,8	159,4	184,4
	qw m³/h	103,47	99,74	95,84	91,87	84,07	77,05	116,77	112,54	108,11	103,58	94,64	86,50
	dpw kPa	192,5	178,8	165,1	151,7	127,1	106,7	143,3	133,1	122,9	112,8	94,1	78,7

Ta /R.U. = Outdoor air temperature (°C)/Relative humidity (%)

Twout = Outlet water temperature (°C);

Pt = Heating capacity (kW);

Pa = Compressors power input (kW) ;

qw = Water flow (m³/h);

dpw = Pressure drop (kPa).

Water flow and pressure drop on heat exchanger calculated with $\Delta T = 5^\circ\text{C}$.

(1) Units equipped with the accessory High Performance temperature (HPT), with outlet water temperature up to 65°C.

MULTIPIPE CHILLER RTMA

HEATING CAPACITY PERFORMANCE

RTMA LN

Ta /R.U		120						130					
		Twout						Twout					
		30°C	35°C	40°C	45°C	55°C	65°C (1)	30°C	35°C	40°C	45°C	55°C	65°C (1)
-5°C / 90 %	Pt kW	367,8	352,0	336,6	322,2	299,1	287,6	403,4	390,6	377,8	365,6	344,6	331,0
	Pat kW	88,8	96,2	104,5	113,4	133,0	154,3	98,1	106,3	115,5	125,8	149,5	177,2
	qw m³/h	63,25	60,54	57,90	55,43	51,45	49,47	69,38	67,18	64,99	62,89	59,27	56,94
	dpw kPa	40,0	36,6	33,5	30,7	26,4	24,4	45,1	42,3	39,6	37,1	32,9	30,4
0°C / 90 %	Pt kW	440,9	422,6	404,2	386,5	355,4	334,3	475,9	460,7	445,3	430,0	401,7	379,5
	Pat kW	93,8	101,2	109,6	118,8	139,3	161,8	102,7	110,9	120,3	130,9	155,7	185,0
	qw m³/h	75,84	72,68	69,52	66,47	61,12	57,50	81,85	79,24	76,59	73,96	69,10	65,27
	dpw kPa	57,5	52,8	48,3	44,1	37,3	33,0	62,8	58,9	55,0	51,3	44,8	39,9
7°C / 90 %	Pt kW	556,6	534,7	512,1	489,6	447,4	413,1	591,2	572,5	552,9	533,0	494,1	459,1
	Pat kW	101,5	108,8	117,2	126,5	147,7	171,5	110,2	118,1	127,5	138,3	163,9	194,8
	qw m³/h	95,74	91,96	88,08	84,22	76,96	71,05	101,69	98,46	95,10	91,68	84,98	78,97
	dpw kPa	91,6	84,5	77,5	70,8	59,2	50,4	97,0	90,9	84,8	78,8	67,7	58,5
10°C / 90 %	Pt kW	612,4	588,8	564,4	539,8	492,7	452,6	647,5	627,0	605,6	583,5	539,6	498,8
	Pat kW	105,2	112,4	120,6	130,0	151,3	175,6	114,0	121,7	131,0	141,7	167,5	199,0
	qw m³/h	105,33	101,27	97,07	92,85	84,75	77,84	111,36	107,85	104,15	100,37	92,81	85,80
	dpw kPa	110,8	102,4	94,1	86,1	71,8	60,5	116,3	109,1	101,7	94,4	80,8	69,0
15°C / 90 %	Pt kW	711,7	685,5	658,0	629,9	574,7	524,8	749,3	725,8	701,0	675,2	622,7	571,9
	Pat kW	111,9	118,7	126,7	135,9	157,4	182,2	121,2	128,5	137,4	148,0	173,8	205,8
	qw m³/h	122,42	117,90	113,17	108,35	98,85	90,27	128,88	124,84	120,57	116,14	107,11	98,37
	dpw kPa	149,7	138,9	127,9	117,3	97,6	81,4	155,7	146,1	136,3	126,5	107,6	90,7

Ta /R.U. = Outdoor air temperature (°C)/Relative humidity (%)

Twout = Outlet water temperature (°C);

Pt = Heating capacity (kW);

Pa = Compressors power input (kW) ;

qw = Water flow (m³/h);

dpw = Pressure drop (kPa).

Water flow and pressure drop on heat exchanger calculated with $\Delta T = 5$ °C.

(1) Units equipped with the accessory High Performance temperature (HPT), with outlet water temperature up to 65°C.

HEATING CAPACITY PERFORMANCE

RTMA LN

Ta /R.U		150						170					
		Twout						Twout					
		30°C	35°C	40°C	45°C	55°C	65°C (1)	30°C	35°C	40°C	45°C	55°C	65°C (1)
-5°C / 90 %	Pt kW	453,1	442,7	432,3	422,0	403,5	389,5	517,7	505,6	493,3	481,1	458,4	440,3
	Pat kW	110,3	119,4	129,9	141,9	170,1	204,7	123,4	133,6	145,4	158,9	190,8	229,9
	qw m³/h	77,93	76,15	74,35	72,59	69,39	67,00	89,04	86,96	84,84	82,74	78,84	75,73
	dpw kPa	51,9	49,5	47,2	45,0	41,1	38,3	64,2	61,3	58,3	55,5	50,3	46,5
0°C / 90 %	Pt kW	529,0	516,6	503,6	490,5	465,0	442,7	603,9	589,3	574,0	558,4	527,8	500,2
	Pat kW	114,6	123,8	134,6	146,9	176,6	213,3	128,3	138,6	150,6	164,5	197,9	239,2
	qw m³/h	91,00	88,85	86,62	84,37	79,98	76,14	103,86	101,35	98,73	96,05	90,78	86,03
	dpw kPa	70,7	67,4	64,1	60,8	54,6	49,5	87,4	83,2	79,0	74,7	66,8	60,0
7°C / 90 %	Pt kW	651,1	635,0	617,8	600,0	563,6	528,2	742,3	723,5	703,4	682,4	639,2	596,8
	Pat kW	121,8	130,8	141,6	154,2	185,1	224,0	136,8	146,8	158,7	172,7	207,3	250,9
	qw m³/h	111,99	109,22	106,27	103,20	96,93	90,86	127,68	124,43	120,98	117,37	109,95	102,66
	dpw kPa	107,1	101,9	96,5	91,0	80,2	70,5	132,0	125,4	118,6	111,6	97,9	85,4
10°C / 90 %	Pt kW	711,4	693,5	674,3	654,1	612,4	570,8	810,8	789,8	767,3	743,7	694,5	645,1
	Pat kW	125,7	134,5	145,1	157,7	188,9	228,5	141,4	151,0	162,8	176,8	211,6	255,8
	qw m³/h	122,37	119,28	115,97	112,51	105,33	98,19	139,45	135,84	131,97	127,91	119,45	110,95
	dpw kPa	127,9	121,5	114,9	108,1	94,8	82,3	157,5	149,5	141,1	132,5	115,6	99,7
15°C / 90 %	Pt kW	822,3	800,9	777,9	753,5	702,3	649,8	936,4	911,4	884,6	856,2	796,2	734,5
	Pat kW	133,4	141,6	151,9	164,3	195,6	236,0	150,5	159,5	170,7	184,4	219,2	264,2
	qw m³/h	141,43	137,75	133,79	129,61	120,79	111,76	161,06	156,76	152,15	147,26	136,95	126,33
	dpw kPa	170,8	162,1	152,9	143,5	124,6	106,7	210,1	199,1	187,5	175,7	151,9	129,3

Ta /R.U. = Outdoor air temperature (°C)/Relative humidity (%)

Twout = Outlet water temperature (°C);

Pt = Heating capacity (kW);

Pa = Compressors power input (kW) ;

qw = Water flow (m³/h);

dpw = Pressure drop (kPa).

Water flow and pressure drop on heat exchanger calculated with $\Delta T = 5 \text{ }^\circ\text{C}$.

(1) Units equipped with the accessory High Performance temperature (HPT), with outlet water temperature up to 65°C.

MULTIPIPE CHILLER RTMA

HEATING CAPACITY PERFORMANCE

RTMA LN

Ta /R.U		180							190						
		Twout							Twout						
		30°C	35°C	40°C	45°C	55°C	65°C (1)	30°C	35°C	40°C	45°C	55°C	65°C (1)		
-5°C / 90 %	Pt kW	532,8	520,5	508,1	496,1	474,8	459,5	549,1	536,5	523,6	510,8	487,3	468,8		
	Pat kW	131,4	142,4	154,9	169,2	202,8	243,7	139,1	150,6	163,8	178,9	214,7	258,6		
	qw m³/h	91,63	89,52	87,40	85,34	81,66	79,03	94,45	92,27	90,05	87,86	83,81	80,63		
	dpw kPa	66,1	63,0	60,1	57,3	52,5	49,1	27,4	26,2	25,0	23,8	21,6	20,0		
0°C / 90 %	Pt kW	622,6	607,8	592,5	577,1	547,4	522,0	640,7	625,5	609,5	593,3	561,4	532,8		
	Pat kW	136,4	147,5	160,5	175,3	210,7	254,3	144,6	156,1	169,7	185,2	222,7	269,2		
	qw m³/h	107,09	104,54	101,91	99,25	94,16	89,78	110,20	107,58	104,84	102,04	96,55	91,64		
	dpw kPa	90,2	86,0	81,7	77,5	69,7	63,4	37,4	35,6	33,8	32,0	28,7	25,8		
7°C / 90 %	Pt kW	766,9	747,7	727,4	706,4	663,6	622,5	787,9	768,2	747,2	725,2	680,1	635,9		
	Pat kW	144,7	155,6	168,7	183,8	220,9	267,4	154,1	165,3	178,7	194,5	233,4	282,4		
	qw m³/h	131,90	128,61	125,12	121,50	114,14	107,07	135,52	132,13	128,51	124,74	116,98	109,38		
	dpw kPa	136,9	130,1	123,2	116,1	102,5	90,2	56,5	53,7	50,8	47,9	42,1	36,8		
10°C / 90 %	Pt kW	838,3	816,9	794,1	770,3	721,1	672,6	860,7	838,7	815,2	790,4	739,0	687,4		
	Pat kW	149,1	159,8	172,7	187,9	225,4	272,8	159,2	170,1	183,3	199,0	238,2	288,0		
	qw m³/h	144,18	140,50	136,59	132,49	124,03	115,69	148,04	144,26	140,21	135,96	127,10	118,23		
	dpw kPa	163,5	155,3	146,8	138,1	121,0	105,3	67,4	64,0	60,5	56,9	49,7	43,0		
15°C / 90 %	Pt kW	969,3	943,9	916,5	887,7	827,1	765,4	994,3	968,1	940,0	910,2	847,4	782,7		
	Pat kW	157,9	168,0	180,5	195,5	233,3	281,7	169,4	179,5	192,2	207,6	246,7	297,4		
	qw m³/h	166,72	162,34	157,64	152,68	142,26	131,64	171,01	166,52	161,68	156,56	145,75	134,62		
	dpw kPa	218,7	207,3	195,5	183,4	159,2	136,3	90,0	85,3	80,4	75,4	65,4	55,8		

Ta /R.U. = Outdoor air temperature (°C)/Relative humidity (%)

Twout = Outlet water temperature (°C);

Pt = Heating capacity (kW);

Pa = Compressors power input (kW) ;

qw = Water flow (m³/h);

dpw = Pressure drop (kPa).

Water flow and pressure drop on heat exchanger calculated with $\Delta T = 5$ °C.

(1) Units equipped with the accessory High Performance temperature (HPT), with outlet water temperature up to 65°C.

HEATING CAPACITY PERFORMANCE

RTMA LN

Ta /R.U			210					
			Twout					
			30°C	35°C	40°C	45°C	55°C	65°C (1)
-5°C / 90 %	Pt	kW	620,8	606,5	592,0	577,6	550,9	530,0
	Pat	kW	151,9	164,5	178,9	195,4	234,5	282,5
	qw	m ³ /h	106,78	104,32	101,82	99,34	94,76	91,16
	dpw	kPa	34,4	32,9	31,3	29,8	27,1	25,1
0°C / 90 %	Pt	kW	716,9	699,9	682,1	664,0	628,7	597,1
	Pat	kW	157,5	170,1	184,9	201,8	242,7	293,2
	qw	m ³ /h	124,13	121,44	118,60	115,67	109,92	104,79
	dpw	kPa	46,5	44,5	42,5	40,4	36,5	33,1
7°C / 90 %	Pt	kW	890,8	868,5	844,8	820,0	769,0	719,0
	Pat	kW	168,3	180,5	195,2	212,4	254,9	308,4
	qw	m ³ /h	153,22	149,39	145,30	141,03	132,26	123,67
	dpw	kPa	70,9	67,4	63,7	60,0	52,8	46,2
10°C / 90 %	Pt	kW	973,1	948,3	921,6	893,7	835,5	777,2
	Pat	kW	173,9	185,8	200,2	217,4	260,1	314,5
	qw	m ³ /h	167,37	163,10	158,52	153,72	143,71	133,67
	dpw	kPa	84,6	80,3	75,9	71,3	62,3	53,9
15°C / 90 %	Pt	kW	1124,1	1094,6	1062,8	1029,1	958,1	884,9
	Pat	kW	185,0	196,0	209,9	226,7	269,5	324,8
	qw	m ³ /h	193,35	188,27	182,80	177,01	164,79	152,20
	dpw	kPa	112,8	107,0	100,9	94,6	82,0	69,9

Ta /R.U. = Outdoor air temperature (°C)/Relative humidity (%)

Twout = Outlet water temperature (°C);

Pt = Heating capacity (kW);

Pa = Compressors power input (kW) ;

qw = Water flow (m³/h);

dpw = Pressure drop (kPa).

Water flow and pressure drop on heat exchanger calculated with $\Delta T = 5^\circ\text{C}$.

(1) Units equipped with the accessory High Performance temperature (HPT), with outlet water temperature up to 65°C.

MULTIPIPE CHILLER RTMA

RECOVERY CAPACITY PERFORMANCE

RTMA LN

Twout			105						115					
			Twoutr						Twoutr					
			30°C	35°C	40°C	45°C	55°C	65°C (1)	30°C	35°C	40°C	45°C	55°C	65°C (1)
6°C	Pf	kW	438,6	411,6	383,2	354,1	325,1	296,9	485,2	455,7	424,3	391,8	359,0	326,7
	Pa	kW	89,9	96,5	104,0	112,5	121,7	131,6	101,5	108,6	116,8	126,1	136,2	147,2
	qw	m³/h	75,45	70,80	65,91	60,91	55,92	51,07	83,46	78,38	72,98	67,40	61,75	56,19
	dpw	kPa	97,3	85,7	74,3	63,4	53,5	44,6	70,1	61,8	53,6	45,7	38,4	31,8
	Pr	kW	528,5	508,1	487,2	466,6	446,8	428,5	586,8	564,3	541,2	517,9	495,3	473,8
	qwr	m³/h	90,90	87,39	83,80	80,25	76,85	73,70	100,93	97,07	93,08	89,08	85,18	81,50
	dpwr	kPa	141,3	130,6	120,1	110,1	101,0	92,9	102,5	94,8	87,2	79,8	73,0	66,8
7°C	Pf	kW	455,0	427,5	398,5	368,7	338,9	309,8	502,7	472,7	440,8	407,7	374,0	340,8
	Pa	kW	90,9	97,5	105,0	113,5	122,7	132,7	102,8	109,8	118,0	127,2	137,4	148,3
	qw	m³/h	78,26	73,52	68,54	63,42	58,29	53,29	86,47	81,31	75,81	70,12	64,33	58,61
	dpw	kPa	104,7	92,4	80,3	68,8	58,1	48,6	75,2	66,5	57,8	49,5	41,6	34,6
	Pr	kW	545,9	524,9	503,5	482,2	461,7	442,5	605,5	582,5	558,7	534,9	511,4	489,1
	qwr	m³/h	93,89	90,29	86,60	82,94	79,41	76,11	104,15	100,19	96,10	92,00	87,96	84,13
	dpwr	kPa	150,8	139,4	128,3	117,6	107,8	99,1	109,1	101,0	92,9	85,2	77,8	71,2
8°C	Pf	kW	471,6	443,7	414,1	383,6	353,1	323,1	520,6	490,1	457,6	423,7	389,4	355,2
	Pa	kW	92,0	98,5	106,1	114,5	123,8	133,8	104,0	111,0	119,1	128,3	138,5	149,5
	qw	m³/h	81,12	76,31	71,22	65,99	60,73	55,58	89,54	84,30	78,70	72,88	66,97	61,10
	dpw	kPa	112,5	99,6	86,7	74,5	63,1	52,8	80,7	71,5	62,3	53,4	45,1	37,6
	Pr	kW	563,6	542,2	520,1	498,2	476,9	456,9	624,6	601,1	576,7	552,1	527,9	504,7
	qwr	m³/h	96,94	93,25	89,47	85,68	82,02	78,59	107,43	103,38	99,19	94,95	90,79	86,82
	dpwr	kPa	160,7	148,7	136,9	125,6	115,1	105,6	116,1	107,5	99,0	90,7	82,9	75,8
9°C	Pf	kW	488,7	460,2	430,0	398,9	367,6	336,8	538,8	507,8	474,7	440,2	405,1	370,0
	Pa	kW	93,1	99,6	107,1	115,6	124,8	134,9	105,3	112,2	120,3	129,5	139,7	150,7
	qw	m³/h	84,05	79,15	73,97	68,62	63,23	57,93	92,67	87,34	81,65	75,71	69,67	63,65
	dpw	kPa	120,8	107,1	93,6	80,5	68,4	57,4	86,4	76,8	67,1	57,7	48,8	40,8
	Pr	kW	581,7	559,8	537,1	514,5	492,4	471,7	644,0	620,0	595,0	569,7	544,7	520,7
	qwr	m³/h	100,06	96,28	92,39	88,49	84,70	81,12	110,77	106,64	102,34	97,98	93,69	89,57
	dpwr	kPa	171,2	158,5	146,0	133,9	122,7	112,5	123,5	114,4	105,4	96,6	88,3	80,7
10°C	Pf	kW	506,0	477,1	446,3	414,6	382,5	350,8	557,3	525,9	492,2	457,0	421,1	385,2
	Pa	kW	94,2	100,7	108,2	116,6	125,9	136,0	106,5	113,4	121,5	130,6	140,8	151,9
	qw	m³/h	87,03	82,06	76,77	71,31	65,79	60,34	95,86	90,45	84,66	78,61	72,43	66,26
	dpw	kPa	129,5	115,1	100,8	87,0	74,0	62,3	92,5	82,3	72,1	62,2	52,8	44,2
	Pr	kW	600,2	577,7	554,5	531,2	508,4	486,8	663,8	639,3	613,7	587,7	561,9	537,1
	qwr	m³/h	103,23	99,37	95,37	91,36	87,44	83,72	114,18	109,96	105,55	101,08	96,65	92,38
	dpwr	kPa	182,3	168,9	155,6	142,7	130,8	119,9	131,2	121,7	112,1	102,8	94,0	85,9
11°C	Pf	kW	523,7	494,3	463,0	430,6	397,7	365,2	576,2	544,3	510,0	474,2	437,5	400,7
	Pa	kW	95,3	101,7	109,2	117,7	127,0	137,0	107,9	114,7	122,7	131,8	142,0	153,1
	qw	m³/h	90,08	85,02	79,64	74,06	68,40	62,81	99,10	93,62	87,73	81,56	75,25	68,93
	dpw	kPa	138,8	123,6	108,5	93,8	80,0	67,5	98,8	88,2	77,4	66,9	57,0	47,8
	Pr	kW	619,0	596,0	572,2	548,2	524,7	502,2	684,0	658,9	632,7	606,0	579,5	553,8
	qwr	m³/h	106,47	102,52	98,42	94,29	90,24	86,38	117,65	113,34	108,82	104,23	99,67	95,25
	dpwr	kPa	193,9	179,7	165,7	152,0	139,3	127,6	139,3	129,3	119,2	109,3	100,0	91,3

- Twout** = Outlet water temperature (°C);
- Twoutr** = Heating side heat exchanger leaving water temperature (°C);
- Pf** = Cooling capacity (kW);
- Pr** = Recovery mode heating capacity (kW);
- Pa** = Compressors heating capacity (kW) ;
- qw** = Water flow (m³/h); dpw = Pressure drop (kPa);
- qwr** = Recovery heat exchanger water flow (m³/h);
- dpw** = Recovery heat exchanger pressure drop (kPa).

Water flow and pressure drop on heat exchanger calculated with $\Delta T = 5^\circ\text{C}$.

(1) Units equipped with the accessory High Performance temperature (HPT), with outlet water temperature up to 65°C.

RECOVERY CAPACITY PERFORMANCE

RTMA LN

Twout		120							130						
		Twoutr							Twoutr						
		30°C	35°C	40°C	45°C	55°C	65°C (1)	30°C	35°C	40°C	45°C	55°C	65°C (1)		
6°C	Pf	kW	506,1	475,4	442,9	409,5	375,9	343,0	537,3	508,9	478,4	446,4	413,6	380,4	
	Pa	kW	98,5	105,5	113,6	122,7	132,6	143,3	107,5	115,7	125,2	136,0	148,2	161,6	
	qw	m³/h	87,05	81,77	76,18	70,43	64,65	58,99	92,41	87,52	82,28	76,79	71,14	65,44	
	dpw	kPa	72,5	64,0	55,5	47,5	40,0	33,3	76,7	68,8	60,8	52,9	45,4	38,4	
	Pr	kW	604,6	580,9	556,5	532,2	508,5	486,3	644,8	624,6	603,6	582,5	561,8	542,0	
	qwr	m³/h	103,99	99,92	95,72	91,53	87,47	83,65	110,91	107,42	103,82	100,18	96,62	93,23	
	dpwr	kPa	103,5	95,5	87,7	80,2	73,2	67,0	110,5	103,6	96,8	90,1	83,8	78,0	
7°C	Pf	kW	524,5	493,3	460,2	426,0	391,6	357,7	556,4	527,4	496,3	463,5	429,7	395,5	
	Pa	kW	99,7	106,6	114,7	132,9	133,8	144,5	108,6	116,8	126,3	137,1	149,3	162,8	
	qw	m³/h	90,22	84,84	79,15	73,27	67,35	61,53	95,70	90,72	85,36	79,72	73,91	68,03	
	dpw	kPa	77,9	68,9	60,0	51,4	43,4	36,2	82,2	73,9	65,4	57,1	49,1	41,6	
	Pr	kW	624,2	599,9	574,9	558,9	525,3	502,2	665,1	644,2	622,5	600,6	579,0	558,3	
	qwr	m³/h	107,36	103,19	98,88	96,13	90,36	86,38	114,39	110,80	107,07	103,30	99,59	96,03	
	dpwr	kPa	110,3	101,9	93,6	88,4	78,1	71,4	117,5	110,2	102,9	95,8	89,1	82,8	
8°C	Pf	kW	543,3	511,5	477,8	442,9	407,6	372,8	576,0	546,4	514,6	481,0	446,3	411,1	
	Pa	kW	100,9	107,8	115,8	124,9	134,9	145,7	109,8	117,8	127,3	138,2	150,4	163,9	
	qw	m³/h	93,45	87,98	82,18	76,18	70,11	64,13	99,08	93,99	88,51	82,73	76,76	70,70	
	dpw	kPa	83,6	74,1	64,6	55,5	47,0	39,4	88,1	79,3	70,3	61,5	52,9	44,9	
	Pr	kW	644,1	619,3	593,6	567,8	542,5	518,5	685,8	664,3	641,9	619,2	596,7	575,0	
	qwr	m³/h	110,79	106,52	102,11	97,66	93,32	89,18	117,96	114,26	110,41	106,50	102,63	98,90	
	dpwr	kPa	117,5	108,6	99,8	91,3	83,3	76,1	124,9	117,2	109,5	101,8	94,6	87,8	
9°C	Pf	kW	562,4	530,2	495,8	460,2	424,1	388,3	596,1	565,9	533,3	498,9	463,3	427,0	
	Pa	kW	102,1	109,0	117,0	126,0	136,0	146,9	111,0	119,0	128,4	139,3	151,5	165,1	
	qw	m³/h	96,74	91,19	85,28	79,15	72,94	66,79	102,52	97,33	91,73	85,82	79,69	73,45	
	dpw	kPa	89,6	79,6	69,6	60,0	50,9	42,7	94,4	85,1	75,6	66,1	57,0	48,4	
	Pr	kW	664,5	639,1	612,8	586,2	560,1	535,2	707,0	684,9	661,8	638,2	614,8	592,2	
	qwr	m³/h	114,29	109,93	105,40	100,83	96,34	92,05	121,61	117,80	113,82	109,78	105,75	101,85	
	dpwr	kPa	125,0	115,6	106,3	97,3	88,8	81,1	132,8	124,6	116,3	108,2	100,4	93,1	
10°C	Pf	kW	581,9	549,2	514,2	477,8	440,9	404,2	616,6	585,8	552,5	517,3	480,8	443,4	
	Pa	kW	103,3	110,2	118,1	127,2	137,2	148,0	112,2	120,1	129,5	140,4	152,7	166,3	
	qw	m³/h	100,09	94,45	88,44	82,19	75,83	69,52	106,05	100,76	95,04	88,98	82,69	76,27	
	dpw	kPa	95,9	85,4	74,9	64,6	55,0	46,3	101,0	91,2	81,1	71,1	61,4	52,2	
	Pr	kW	685,3	659,3	632,3	605,0	578,1	552,2	728,7	705,9	682,1	657,7	633,4	609,8	
	qwr	m³/h	82,23	79,12	75,88	72,60	69,37	66,27	87,45	84,71	81,85	78,93	76,01	73,17	
	dpwr	kPa	64,7	59,9	55,1	50,4	46,1	42,0	68,7	64,4	60,2	55,9	51,9	48,1	
11°C	Pf	kW	601,8	568,5	532,9	495,9	458,1	420,5	637,6	606,2	572,2	536,2	498,7	460,3	
	Pa	kW	104,6	111,4	119,3	128,3	138,3	149,2	113,4	121,3	130,7	141,5	153,8	167,5	
	qw	m³/h	103,51	97,79	91,67	85,29	78,79	72,32	109,66	104,27	98,42	92,22	85,77	79,16	
	dpw	kPa	102,5	91,5	80,4	69,6	59,4	50,1	108,0	97,6	87,0	76,4	66,1	56,3	
	Pr	kW	706,4	679,9	652,3	624,2	596,4	569,7	751,0	727,5	702,9	677,7	652,5	627,8	
	qwr	m³/h	121,50	116,94	112,19	107,36	102,59	97,98	129,17	125,13	120,90	116,57	112,23	107,98	
	dpwr	kPa	141,3	130,9	120,4	110,3	100,7	91,9	149,8	140,6	131,2	122,0	113,1	104,7	

- Twout** = Outlet water temperature (°C);
- Twoutr** = Heating side heat exchanger leaving water temperature (°C);
- Pf** = Cooling capacity (kW);
- Pr** = Recovery mode heating capacity (kW);
- Pa** = Compressors heating capacity (kW) ;
- qw** = Water flow (m³/h); dpw = Pressure drop (kPa);
- qwr** = Recovery heat exchanger water flow (m³/h);
- dpw** = Recovery heat exchanger pressure drop (kPa).

Water flow and pressure drop on heat exchanger calculated with $\Delta T = 5\text{ °C}$

(1) Units equipped with the accessory High Performance temperature (HPT), with outlet water temperature up to 65°C.

MULTIPIPE CHILLER RTMA

RECOVERY CAPACITY PERFORMANCE

RTMA LN

Twout			150						170					
			Twoutr						Twoutr					
			30°C	35°C	40°C	45°C	55°C	65°C (1)	30°C	35°C	40°C	45°C	55°C	65°C (1)
6°C	Pf	kW	599,1	572,6	543,1	511,1	476,7	440,2	671,1	641,7	609,2	573,9	536,2	496,4
	Pa	kW	122,7	131,6	142,4	155,0	169,5	186,0	132,2	142,1	153,9	167,6	183,4	201,3
	qw	m³/h	103,04	98,48	93,42	87,90	81,99	75,72	115,43	110,38	104,78	98,71	92,22	85,38
	dpw	kPa	87,4	79,9	71,9	63,6	55,3	47,2	104,0	95,1	85,7	76,1	66,4	56,9
	Pr	kW	721,7	704,2	685,5	666,0	646,1	626,2	803,3	783,8	763,0	741,5	719,5	697,6
	qwr	m³/h	124,13	121,12	117,91	114,56	111,14	107,71	138,17	134,81	131,24	127,54	123,76	119,99
	dpwr	kPa	126,9	120,8	114,5	108,1	101,7	95,5	149,1	141,9	134,5	127,0	119,6	112,4
7°C	Pf	kW	619,3	592,2	562,1	529,2	493,9	456,4	693,8	663,8	630,4	594,2	555,4	514,5
	Pa	kW	123,9	132,8	143,5	156,1	170,6	187,2	133,5	143,3	155,0	168,8	184,6	202,6
	qw	m³/h	106,51	101,86	96,68	91,02	84,95	78,50	119,33	114,17	108,43	102,20	95,53	88,49
	dpw	kPa	93,4	85,4	77,0	68,2	59,4	50,7	111,2	101,8	91,8	81,5	71,2	61,1
	Pr	kW	743,1	725,0	705,6	685,3	664,5	643,6	827,3	807,0	785,5	763,0	740,0	717,0
	qwr	m³/h	127,82	124,70	121,36	117,87	114,30	110,70	142,29	138,81	135,10	131,24	127,29	123,33
	dpwr	kPa	134,5	128,0	121,3	114,4	107,6	100,9	158,1	150,4	142,5	134,5	126,5	118,7
8°C	Pf	kW	640,0	612,3	581,5	547,8	511,5	473,0	717,1	686,3	652,2	615,1	575,2	533,0
	Pa	kW	125,2	134,0	144,7	157,3	171,8	188,4	134,8	144,5	156,3	170,0	185,9	203,9
	qw	m³/h	110,08	105,32	100,02	94,22	87,99	81,36	123,33	118,05	112,18	105,79	98,93	91,68
	dpw	kPa	99,8	91,3	82,4	73,1	63,7	54,5	118,8	108,8	98,3	87,4	76,4	65,6
	Pr	kW	765,1	746,3	726,2	705,1	683,4	661,5	851,9	830,9	808,5	785,1	761,1	737,0
	qwr	m³/h	131,61	128,37	124,90	121,27	117,54	113,77	146,52	142,91	139,06	135,03	130,91	126,76
	dpwr	kPa	142,6	135,7	128,5	121,1	113,8	106,6	167,6	159,4	151,0	142,4	133,8	125,4
9°C	Pf	kW	661,2	633,0	601,5	566,9	529,7	490,1	740,9	709,5	674,6	636,5	595,5	552,1
	Pa	kW	126,5	135,2	145,9	158,4	173,0	189,7	136,2	145,8	157,5	171,3	187,2	205,3
	qw	m³/h	113,73	108,87	103,45	97,51	91,11	84,30	127,43	122,04	116,03	109,47	102,43	94,97
	dpw	kPa	106,5	97,6	88,1	78,3	68,3	58,5	126,8	116,3	105,1	93,6	81,9	70,4
	Pr	kW	787,7	768,2	747,3	725,4	702,7	679,8	877,1	855,3	832,1	807,7	782,7	757,4
	qwr	m³/h	135,49	132,13	128,54	124,76	120,87	116,93	150,86	147,12	143,12	138,93	134,63	130,28
	dpwr	kPa	151,2	143,8	136,0	128,2	120,3	112,6	177,7	169,0	159,9	150,7	141,5	132,5
10°C	Pf	kW	683,0	654,2	621,9	586,5	548,3	507,7	765,3	733,3	697,5	658,4	616,4	571,8
	Pa	kW	127,9	136,5	147,1	159,7	174,3	191,0	137,7	147,2	158,8	172,6	188,5	206,7
	qw	m³/h	117,47	112,52	106,97	100,88	94,31	87,32	131,64	126,12	119,97	113,25	106,02	98,35
	dpw	kPa	113,6	104,2	94,2	83,8	73,2	62,8	135,3	124,2	112,4	100,1	87,8	75,5
	Pr	kW	810,9	790,7	769,0	746,2	722,6	698,6	903,0	880,5	856,3	831,0	804,9	778,4
	qwr	m³/h	97,31	94,88	92,28	89,54	86,71	83,84	108,36	105,66	102,76	99,72	96,59	93,41
	dpwr	kPa	78,0	74,1	70,1	66,0	61,9	57,9	91,7	87,2	82,4	77,6	72,8	68,1
11°C	Pf	kW	705,3	675,9	642,9	606,6	567,5	525,7	790,4	757,6	721,0	681,0	637,8	592,0
	Pa	kW	129,4	137,9	148,4	160,9	175,5	192,3	139,2	148,6	160,2	173,9	189,8	208,1
	qw	m³/h	121,31	116,25	110,57	104,34	97,61	90,42	135,95	130,31	124,02	117,13	109,71	101,82
	dpw	kPa	121,2	111,3	100,7	89,6	78,4	67,3	144,3	132,6	120,1	107,1	94,0	80,9
	Pr	kW	834,7	813,8	791,3	767,6	743,0	718,0	929,6	906,2	881,2	854,9	827,7	800,0
	qwr	m³/h	143,57	139,97	136,10	132,02	127,80	123,50	159,89	155,87	151,57	147,04	142,36	137,61
	dpwr	kPa	169,7	161,3	152,5	143,5	134,5	125,6	199,6	189,7	179,3	168,8	158,2	147,8

Twout = Outlet water temperature (°C);
 Twoutr = Heating side heat exchanger leaving water temperature (°C);
 Pf = Cooling capacity (kW);
 Pr = Recovery mode heating capacity (kW);
 Pa = Compressors heating capacity (kW);
 qw = Water flow (m³/h); dpw = Pressure drop (kPa);
 qwr = Recovery heat exchanger water flow (m³/h);
 dpwr = Recovery heat exchanger pressure drop (kPa).

Water flow and pressure drop on heat exchanger calculated with $\Delta T = 5^\circ\text{C}$.

(1) Units equipped with the accessory High Performance temperature (HPT), with outlet water temperature up to 65°C.

RECOVERY CAPACITY PERFORMANCE

RTMA LN

Twout			180						190					
			Twoutr						Twoutr					
			30°C	35°C	40°C	45°C	55°C	65°C (1)	30°C	35°C	40°C	45°C	55°C	65°C (1)
6°C	Pf	kW	708,5	677,0	642,2	604,6	564,5	522,4	753,7	720,6	683,8	643,6	600,4	554,7
	Pa	kW	142,5	153,3	166,2	181,1	198,3	217,6	152,2	163,2	176,4	192,0	209,9	230,3
	qw	m³/h	121,86	116,44	110,46	103,99	97,09	89,84	129,64	123,95	117,61	110,70	103,27	95,40
	dpw	kPa	112,5	102,7	92,4	81,9	71,4	61,1	49,9	45,6	41,0	36,4	31,6	27,0
	Pr	kW	850,9	830,3	808,4	785,7	762,8	740,0	905,9	883,8	860,2	835,6	810,3	785,0
	qwr	m³/h	146,36	142,80	139,04	135,14	131,20	127,27	155,82	152,02	147,96	143,72	139,38	135,01
	dpwr	kPa	162,2	154,5	146,4	138,3	130,4	122,7	72,0	68,6	64,9	61,3	57,6	54,1
7°C	Pf	kW	732,6	700,4	664,8	626,2	585,0	541,5	779,0	745,2	707,5	666,3	622,0	574,9
	Pa	kW	143,8	154,5	167,4	182,4	199,6	219,1	153,8	164,7	177,9	193,4	211,4	231,8
	qw	m³/h	126,01	120,47	114,35	107,71	100,61	93,14	133,99	128,18	121,69	114,60	106,98	98,89
	dpw	kPa	120,3	109,9	99,0	87,9	76,7	65,7	53,3	48,7	43,9	39,0	34,0	29,0
	Pr	kW	876,4	855,0	832,2	808,6	784,6	760,6	932,8	909,9	885,4	859,7	833,3	806,8
	qwr	m³/h	150,74	147,05	143,14	139,08	134,95	130,82	160,44	156,50	152,28	147,87	143,34	138,76
	dpwr	kPa	172,1	163,8	155,2	146,5	137,9	129,6	76,4	72,7	68,8	64,9	61,0	57,1
8°C	Pf	kW	757,4	724,5	688,0	648,4	606,0	561,2	805,0	770,4	731,8	689,6	644,1	595,8
	Pa	kW	145,1	155,8	168,7	183,7	200,9	220,5	155,4	166,2	179,3	194,8	212,8	233,4
	qw	m³/h	130,27	124,61	118,34	111,52	104,23	96,53	138,45	132,51	125,88	118,61	110,79	102,48
	dpw	kPa	128,5	117,6	106,1	94,2	82,3	70,6	56,9	52,1	47,0	41,7	36,4	31,2
	Pr	kW	902,5	880,3	856,7	832,1	806,9	781,8	960,4	936,6	911,2	884,5	857,0	829,1
	qwr	m³/h	155,24	151,42	147,35	143,12	138,79	134,46	165,18	161,10	156,72	152,13	147,40	142,61
	dpwr	kPa	182,5	173,7	164,5	155,1	145,9	136,9	80,9	77,0	72,9	68,7	64,5	60,3
9°C	Pf	kW	782,8	749,2	711,8	671,2	627,6	581,5	831,6	796,3	756,8	713,6	666,9	617,2
	Pa	kW	146,6	157,2	170,0	185,0	202,3	222,0	157,1	167,8	180,8	196,3	214,3	234,9
	qw	m³/h	134,64	128,86	122,43	115,44	107,95	100,02	143,03	136,96	130,17	122,73	114,71	106,16
	dpw	kPa	137,3	125,8	113,5	100,9	88,3	75,8	60,7	55,6	50,3	44,7	39,0	33,4
	Pr	kW	929,4	906,4	881,8	856,2	829,9	803,5	988,7	964,1	937,7	909,9	881,2	852,1
	qwr	m³/h	159,85	155,89	151,67	147,26	142,74	138,20	170,05	165,82	161,28	156,50	151,57	146,57
	dpwr	kPa	193,5	184,1	174,2	164,3	154,3	144,7	85,8	81,6	77,2	72,7	68,2	63,7
10°C	Pf	kW	808,9	774,5	736,2	694,5	649,8	602,4	858,8	822,8	782,4	738,1	690,3	639,2
	Pa	kW	148,1	158,6	171,4	186,4	203,7	223,4	158,9	169,4	182,4	197,9	215,9	236,5
	qw	m³/h	139,12	133,21	126,63	119,46	111,76	103,61	147,72	141,52	134,58	126,96	118,72	109,95
	dpw	kPa	146,6	134,4	121,5	108,1	94,6	81,3	64,7	59,4	53,7	47,8	41,8	35,9
	Pr	kW	956,9	933,1	907,6	880,9	853,5	825,8	1017,7	992,2	964,8	936,0	906,1	875,8
	qwr	m³/h	164,59	160,49	156,11	151,52	146,80	142,04	175,04	170,66	165,95	160,99	155,86	150,63
	dpwr	kPa	205,2	195,1	184,6	173,9	163,2	152,8	90,9	86,4	81,7	76,9	72,1	67,3
11°C	Pf	kW	835,6	800,4	761,3	718,5	672,6	623,8	886,7	849,9	808,7	763,3	714,2	661,9
	Pa	kW	149,6	160,1	172,8	187,8	205,1	224,9	160,8	171,2	184,1	199,5	217,5	238,1
	qw	m³/h	143,72	137,67	130,94	123,59	115,68	107,30	152,52	146,19	139,09	131,29	122,85	113,84
	dpw	kPa	156,4	143,6	129,9	115,7	101,4	87,2	69,0	63,4	57,4	51,1	44,8	38,4
	Pr	kW	985,2	960,5	934,0	906,3	877,7	848,7	1047,5	1021,1	992,7	962,8	931,7	900,0
	qwr	m³/h	169,46	165,21	160,66	155,88	150,96	145,98	180,17	175,63	170,75	165,60	160,26	154,80
	dpwr	kPa	217,5	206,7	195,5	184,1	172,6	161,4	96,3	91,5	86,5	81,4	76,2	71,1

Twout = Outlet water temperature (°C);
 Twoutr = Heating side heat exchanger leaving water temperature (°C);
 Pf = Cooling capacity (kW);
 Pr = Recovery mode heating capacity (kW);
 Pa = Compressors heating capacity (kW);
 qw = Water flow (m³/h); dpw = Pressure drop (kPa);
 qwr = Recovery heat exchanger water flow (m³/h);
 dpw = Recovery heat exchanger pressure drop (kPa).

Water flow and pressure drop on heat exchanger calculated with ΔT= 5 °C.

(1) Units equipped with the accessory High Performance temperature (HPT), with outlet water temperature up to 65°C.

MULTIPIPE CHILLER RTMA

RECOVERY CAPACITY PERFORMANCE

RTMA LN

Twout			210					
			Twoutr					
			30°C	35°C	40°C	45°C	55°C	65°C (1)
6°C	Pf	kW	830,1	793,5	752,8	708,4	660,6	610,1
	Pa	kW	168,8	181,0	195,7	212,9	232,8	255,4
	qw	m³/h	142,77	136,48	129,48	121,84	113,63	104,93
	dpw	kPa	59,3	54,2	48,8	43,2	37,6	32,0
	Pr	kW	998,9	974,5	948,5	921,3	893,5	865,5
	qwr	m³/h	171,81	167,61	163,14	158,46	153,68	148,86
	dpwr	kPa	85,9	81,8	77,5	73,1	68,7	64,5
	7°C	Pf	kW	858,0	820,6	778,9	733,0	684,4
Pa		kW	170,5	182,6	197,3	214,0	234,4	257,1
qw		m³/h	147,57	141,14	133,98	126,08	117,72	108,78
dpw		kPa	63,4	58,0	52,2	46,3	40,3	34,4
Pr		kW	1028,5	1003,2	976,2	947,0	918,8	889,5
qwr		m³/h	176,90	172,55	167,91	162,88	158,04	153,00
dpwr		kPa	91,1	86,7	82,1	77,2	72,7	68,1
8°C		Pf	kW	886,5	848,4	805,8	759,1	708,8
	Pa	kW	172,4	184,3	198,9	216,1	236,1	258,8
	qw	m³/h	152,48	145,92	138,59	130,57	121,92	112,73
	dpw	kPa	67,7	62,0	55,9	49,6	43,3	37,0
	Pr	kW	1058,9	1032,7	1004,6	975,2	944,9	914,2
	qwr	m³/h	182,13	177,62	172,80	167,74	162,52	157,24
	dpwr	kPa	96,5	91,8	86,9	81,9	76,9	72,0
	9°C	Pf	kW	915,8	876,9	833,3	785,5	733,9
Pa		kW	174,2	186,1	200,6	217,8	237,7	260,6
qw		m³/h	157,52	150,82	143,32	135,10	126,23	116,79
dpw		kPa	72,2	66,2	59,8	53,1	46,4	39,7
Pr		kW	1090,1	1063,0	1033,8	1003,2	971,6	939,6
qwr		m³/h	187,49	182,83	177,82	172,56	167,12	161,60
dpwr		kPa	102,3	97,3	92,0	86,7	81,3	76,0
10°C		Pf	kW	945,9	906,1	861,5	812,6	759,7
	Pa	kW	176,2	187,9	202,3	219,5	239,4	262,3
	qw	m³/h	162,69	155,85	148,18	139,76	130,66	120,96
	dpw	kPa	77,0	70,7	63,9	56,9	49,7	42,6
	Pr	kW	1122,1	1094,0	1063,8	1032,0	999,1	965,6
	qwr	m³/h	193,00	188,17	182,98	177,51	171,85	166,08
	dpwr	kPa	108,4	103,1	97,4	91,7	86,0	80,3
	11°C	Pf	kW	976,7	936,0	890,4	840,3	786,1
Pa		kW	178,3	189,8	204,1	221,2	241,2	264,1
qw		m³/h	167,99	161,00	153,16	144,54	135,21	125,25
dpw		kPa	82,1	75,4	68,3	60,8	53,2	45,7
Pr		kW	1155,0	1125,9	1094,6	1061,6	1027,3	992,4
qwr		m³/h	198,66	193,65	188,27	182,59	176,70	170,68
dpwr		kPa	114,9	109,2	103,2	97,0	90,9	84,8

Twout = Outlet water temperature (°C);
Twoutr = Heating side heat exchanger leaving water temperature (°C);
Pf = Cooling capacity (kW);
Pr = Recovery mode heating capacity (kW);
Pa = Compressors heating capacity (kW) ;
qw = Water flow (m³/h); dpw = Pressure drop (kPa);
qwr = Recovery heat exchanger water flow (m³/h);
dpw = Recovery heat exchanger pressure drop (kPa).
 Water flow and pressure drop on heat exchanger calculated with $\Delta T = 5^\circ\text{C}$.

(1) Units equipped with the accessory High Performance temperature (HPT), with outlet water temperature up to 65°C.

COOLING CAPACITY PERFORMANCE

RTMA SL

Twout			105						115					
			Tae						Tae					
			25°C	30°C	32°C	35°C	40°C	43°C	25°C	30°C	32°C	35°C	40°C	43°C
6°C	Pf	kW	414,8	383,5	370,6	351,0	326,5	312,5	451,5	422,0	409,7	391,0	367,4	353,7
	Pa	kW	96,2	104,0	107,4	112,7	120,0	124,4	109,3	117,3	120,8	126,3	133,9	138,5
	qw	m ³ /h	71,35	65,96	63,74	60,37	56,16	53,75	77,65	72,58	70,48	67,26	63,20	60,84
	dpw	kPa	87,0	74,4	69,5	62,3	53,9	49,4	60,7	53,0	50,0	45,5	40,2	37,2
7°C	Pf	kW	430,5	398,4	385,2	365,1	340,0	325,6	466,0	435,9	423,4	404,2	380,1	366,1
	Pa	kW	97,8	105,6	109,0	114,4	121,8	126,2	111,1	119,0	122,6	128,2	135,8	140,5
	qw	m ³ /h	74,04	68,53	66,25	62,79	58,48	56,00	80,15	74,97	72,82	69,53	65,38	62,96
	dpw	kPa	93,8	80,3	75,1	67,4	58,5	53,6	64,6	56,6	53,4	48,6	43,0	39,9
8°C	Pf	kW	446,5	413,7	400,2	379,6	353,8	339,0	480,7	450,0	437,2	417,7	393,0	378,6
	Pa	kW	99,4	107,3	110,7	116,2	123,6	128,1	112,8	120,8	124,4	130,0	137,7	142,4
	qw	m ³ /h	76,81	71,16	68,83	65,28	60,85	58,30	82,69	77,40	75,21	71,85	67,60	65,13
	dpw	kPa	100,9	86,6	81,0	72,9	63,3	58,1	68,8	60,3	56,9	51,9	46,0	42,7
9°C	Pf	kW	463,0	429,4	415,5	394,4	368,0	352,7	495,8	464,4	451,4	431,4	406,2	391,5
	Pa	kW	101,0	108,9	112,4	117,9	125,4	130,0	114,6	122,7	126,2	131,9	139,6	144,3
	qw	m ³ /h	79,53	73,76	71,38	67,75	63,21	60,59	85,16	79,77	77,53	74,11	69,77	67,25
	dpw	kPa	108,2	93,0	87,1	78,5	68,3	62,8	73,0	64,0	60,5	55,3	49,0	45,5
10°C	Pf	kW	479,8	445,4	431,2	409,6	382,5	366,9	511,1	479,0	465,7	445,3	419,5	404,5
	Pa	kW	102,6	110,6	114,1	119,7	127,3	131,9	116,4	124,5	128,1	133,8	141,5	146,3
	qw	m ³ /h	82,52	76,61	74,17	70,45	65,78	63,10	87,90	82,39	80,10	76,60	72,16	69,58
	dpw	kPa	116,5	100,4	94,1	84,9	74,0	68,1	77,7	68,3	64,6	59,0	52,4	48,7
11°C	Pf	kW	497,0	461,8	447,3	425,1	397,3	381,3	526,6	493,9	480,3	459,5	433,2	417,8
	Pa	kW	104,3	112,4	115,9	121,5	129,1	133,8	118,2	126,4	130,0	135,7	143,5	148,3
	qw	m ³ /h	85,48	79,43	76,93	73,12	68,34	65,58	90,57	84,95	82,61	79,04	74,50	71,86
	dpw	kPa	125,0	107,9	101,2	91,4	79,9	73,6	82,5	72,6	68,7	62,9	55,9	52,0

Tae= Outdoor air temperature(°C);
Twout = Outlet water temperature (°C);
Pf = Cooling capacity (kW);
Pa = Compressors power input (kW) ;
qw = Water flow (m³/h);
dpw = Pressure drop (kPa).

Water flow and pressure drop on heat exchanger calculated with $\Delta T= 5\text{ }^{\circ}\text{C}$.

MULTIPIPE CHILLER RTMA

COOLING CAPACITY PERFORMANCE

RTMA SL

Twout		120							130						
		Outdoor air temperature							Outdoor air temperature						
		25°C	30°C	32°C	35°C	40°C	43°C	25°C	30°C	32°C	35°C	40°C	43°C		
6°C	Pf kW	469,8	440,1	427,6	408,6	384,4	370,3	510,3	477,7	464,2	443,4	417,1	401,7		
	Pa kW	106,5	114,1	117,5	122,9	130,3	134,8	116,1	125,6	129,8	136,4	145,5	151,1		
	qw m ³ /h	80,81	75,69	73,56	70,28	66,12	63,70	87,77	82,17	79,84	76,26	71,74	69,10		
	dpw kPa	62,5	54,8	51,8	47,3	41,8	38,8	69,2	60,6	57,2	52,2	46,2	42,9		
7°C	Pf kW	485,0	454,7	442,0	422,5	397,8	383,3	528,3	494,9	481,0	459,6	432,6	416,7		
	Pa kW	108,3	115,9	119,3	124,8	132,2	136,7	117,7	127,3	131,5	138,3	147,5	153,1		
	qw m ³ /h	83,22	78,01	75,83	72,49	68,25	65,77	90,65	84,92	82,53	78,86	74,22	71,51		
	dpw kPa	66,3	58,2	55,0	50,3	44,6	41,4	73,8	64,7	61,2	55,8	49,5	45,9		
8°C	Pf kW	500,5	469,5	456,5	436,6	411,3	396,6	546,8	512,5	498,2	476,2	448,4	432,1		
	Pa kW	110,0	117,7	121,1	126,6	134,1	138,6	119,4	129,1	133,4	140,2	149,5	155,2		
	qw m ³ /h	86,09	80,75	78,52	75,10	70,75	68,22	94,05	88,15	85,69	81,91	77,12	74,32		
	dpw kPa	70,9	62,4	59,0	54,0	47,9	44,5	79,4	69,8	65,9	60,2	53,4	49,6		
9°C	Pf kW	516,3	484,6	471,4	451,0	425,2	410,1	565,7	530,5	515,8	493,3	464,6	447,8		
	Pa kW	111,8	119,5	123,0	128,5	136,0	140,6	121,1	130,9	135,2	142,1	151,5	157,4		
	qw m ³ /h	88,80	83,35	81,07	77,58	73,13	70,54	97,29	91,24	88,72	84,84	79,91	77,02		
	dpw kPa	75,5	66,5	62,9	57,6	51,2	47,6	85,0	74,8	70,7	64,6	57,3	53,3		
10°C	Pf kW	532,3	500,0	486,4	465,7	439,3	423,9	585,0	548,9	533,8	510,7	481,2	463,9		
	Pa kW	113,6	121,4	124,8	130,4	137,9	142,6	122,8	132,7	137,1	144,1	153,6	159,5		
	qw m ³ /h	91,56	86,00	83,67	80,10	75,56	72,90	100,62	94,41	91,82	87,83	82,76	79,79		
	dpw kPa	80,2	70,8	67,0	61,4	54,6	50,9	90,9	80,0	75,7	69,3	61,5	57,2		
11°C	Pf kW	548,6	515,6	501,8	480,6	453,6	437,9	604,7	567,7	552,3	528,5	498,1	480,3		
	Pa kW	115,5	123,2	126,7	132,3	139,9	144,5	124,6	134,6	139,0	146,0	155,7	161,7		
	qw m ³ /h	94,36	88,68	86,31	82,66	78,02	75,31	104,01	97,65	94,99	90,89	85,68	82,62		
	dpw kPa	85,2	75,3	71,3	65,4	58,3	54,3	97,1	85,6	81,0	74,2	65,9	61,3		

Tae= Outdoor air temperature(°C);
Twout = Outlet water temperature (°C);
Pf = Cooling capacity (kW);
Pa = Compressors power input (kW) ;
qw = Water flow (m³/h);
dpw = Pressure drop (kPa).

Water flow and pressure drop on heat exchanger calculated with $\Delta T= 5\text{ }^{\circ}\text{C}$.

COOLING CAPACITY PERFORMANCE
RTMA SL

Twout			150						170					
			Outdoor air temperature						Outdoor air temperature					
			25°C	30°C	32°C	35°C	40°C	43°C	25°C	30°C	32°C	35°C	40°C	43°C
6°C	Pf	kW	569,9	541,2	529,0	509,8	484,7	469,5	640,4	607,9	594,0	572,2	543,8	526,7
	Pa	kW	132,6	143,1	147,8	155,4	166,0	172,7	143,3	154,6	159,8	168,1	179,6	186,8
	qw	m ³ /h	98,02	93,09	90,98	87,68	83,36	80,76	110,14	104,55	102,16	98,42	93,53	90,59
	dpw	kPa	79,1	71,4	68,2	63,3	57,2	53,7	94,7	85,3	81,5	75,6	68,3	64,1
7°C	Pf	kW	587,4	558,0	545,3	525,6	499,7	484,1	660,3	626,8	612,5	590,1	560,8	543,2
	Pa	kW	134,5	145,0	149,8	157,5	168,2	175,0	145,3	156,7	161,9	170,3	182,0	189,3
	qw	m ³ /h	101,04	95,97	93,80	90,40	85,95	83,26	113,56	107,81	105,35	101,49	96,46	93,42
	dpw	kPa	84,1	75,8	72,4	67,3	60,8	57,1	100,7	90,7	86,6	80,4	72,6	68,1
8°C	Pf	kW	605,4	575,1	562,1	541,7	515,0	499,0	680,6	646,2	631,4	608,3	578,1	560,0
	Pa	kW	136,4	147,0	151,8	159,6	170,4	177,3	147,3	158,9	164,1	172,6	184,4	191,8
	qw	m ³ /h	104,13	98,91	96,68	93,17	88,59	85,82	117,06	111,14	108,61	104,64	99,44	96,31
	dpw	kPa	89,3	80,6	77,0	71,5	64,6	60,6	107,0	96,4	92,1	85,5	77,2	72,4
9°C	Pf	kW	623,8	592,6	579,2	558,2	530,7	514,2	701,4	666,0	650,8	627,0	595,9	577,1
	Pa	kW	138,4	149,1	153,9	161,7	172,7	179,6	149,4	161,1	166,3	174,9	186,8	194,3
	qw	m ³ /h	107,16	101,79	99,49	95,89	91,17	88,32	120,49	114,40	111,79	107,71	102,36	99,14
	dpw	kPa	94,5	85,3	81,5	75,7	68,4	64,2	113,3	102,2	97,6	90,6	81,8	76,7
10°C	Pf	kW	642,6	610,4	596,7	575,1	546,7	529,7	722,7	686,2	670,6	646,1	614,0	594,7
	Pa	kW	140,4	151,2	156,0	163,9	175,0	182,0	151,6	163,3	168,6	177,2	189,3	196,9
	qw	m ³ /h	110,53	105,00	102,63	98,91	94,04	91,11	124,30	118,02	115,34	111,12	105,61	102,29
	dpw	kPa	100,6	90,8	86,7	80,6	72,8	68,3	120,6	108,7	103,9	96,4	87,1	81,7
11°C	Pf	kW	661,8	628,7	614,5	592,3	563,1	545,5	744,4	706,8	690,8	665,5	632,5	612,6
	Pa	kW	142,5	153,3	158,2	166,2	177,4	184,5	153,8	165,6	170,9	179,7	191,8	199,5
	qw	m ³ /h	113,83	108,14	105,70	101,87	96,86	93,83	128,04	121,58	118,81	114,47	108,79	105,37
	dpw	kPa	106,7	96,3	92,0	85,5	77,2	72,5	128,0	115,4	110,2	102,3	92,4	86,7

Tae= Outdoor air temperature(°C);
Twout = Outlet water temperature (°C);
Pf = Cooling capacity (kW);
Pa = Compressors power input (kW) ;
qw = Water flow (m³/h);
dpw = Pressure drop (kPa).

Water flow and pressure drop on heat exchanger calculated with $\Delta T= 5\text{ }^{\circ}\text{C}$.

MULTIPIPE CHILLER RTMA

COOLING CAPACITY PERFORMANCE

RTMA SL

Twout			180						190					
			Tae											
			25°C	30°C	32°C	35°C	40°C	43°C	25°C	30°C	32°C	35°C	40°C	43°C
6°C	Pf	kW	676,2	640,2	624,9	601,2	570,5	552,2	717,1	681,3	666,0	642,0	610,5	591,6
	Pa	kW	154,4	167,1	172,7	181,7	194,2	201,9	164,5	177,3	183,1	192,5	205,6	213,9
	qw	m ³ /h	116,31	110,11	107,49	103,41	98,13	94,98	123,34	117,19	114,55	110,42	105,01	101,75
	dpw	kPa	102,5	91,8	87,5	81,0	72,9	68,3	45,1	40,7	38,9	36,2	32,7	30,7
7°C	Pf	kW	698,9	661,9	646,2	621,7	590,1	571,2	739,1	702,3	686,5	661,8	629,3	609,8
	Pa	kW	156,3	169,2	174,9	184,0	196,7	204,6	166,8	179,7	185,6	195,1	208,3	216,7
	qw	m ³ /h	120,21	113,84	111,14	106,94	101,49	98,24	127,13	120,79	118,08	113,82	108,25	104,89
	dpw	kPa	109,4	98,2	93,6	86,6	78,0	73,1	47,9	43,3	41,4	38,4	34,8	32,6
8°C	Pf	kW	722,1	684,0	667,9	642,7	610,0	590,5	761,6	723,7	707,5	682,0	648,6	628,5
	Pa	kW	158,3	171,3	177,1	186,4	199,2	207,2	169,2	182,2	188,1	197,7	211,1	219,6
	qw	m ³ /h	124,20	117,65	114,87	110,54	104,92	101,57	131,00	124,48	121,68	117,30	111,56	108,09
	dpw	kPa	116,8	104,8	99,9	92,6	83,4	78,1	50,9	46,0	43,9	40,8	36,9	34,7
9°C	Pf	kW	745,8	706,7	690,1	664,1	630,4	610,3	784,6	745,6	728,9	702,6	668,2	647,5
	Pa	kW	160,4	173,5	179,3	188,8	201,8	209,9	171,7	184,8	190,7	200,4	214,0	222,5
	qw	m ³ /h	128,28	121,55	118,69	114,23	108,43	104,96	134,96	128,24	125,36	120,85	114,93	111,37
	dpw	kPa	124,6	111,9	106,7	98,8	89,1	83,5	54,0	48,8	46,6	43,3	39,2	36,8
10°C	Pf	kW	770,2	729,9	712,8	686,0	651,3	630,5	808,1	768,0	750,7	723,7	688,3	666,9
	Pa	kW	162,4	175,7	181,6	191,2	204,4	212,7	174,2	187,4	193,4	203,2	216,8	225,5
	qw	m ³ /h	132,47	125,54	122,60	118,00	112,02	108,44	139,00	132,09	129,13	124,48	118,39	114,71
	dpw	kPa	132,9	119,4	113,8	105,5	95,0	89,1	57,3	51,8	49,5	46,0	41,6	39,0
11°C	Pf	kW	795,1	753,6	736,0	708,4	672,6	651,1	832,2	790,8	773,1	745,3	708,8	686,8
	Pa	kW	164,6	178,0	184,0	193,6	207,0	215,4	176,9	190,1	196,1	206,0	219,8	228,5
	qw	m ³ /h	136,75	129,63	126,59	121,85	115,69	111,99	143,14	136,02	132,97	128,19	121,91	118,13
	dpw	kPa	141,6	127,3	121,4	112,5	101,4	95,0	60,8	54,9	52,5	48,7	44,1	41,4

Tae= Outdoor air temperature(°C);
Twout = Outlet water temperature (°C);
Pf = Cooling capacity (kW);
Pa = Compressors power input (kW) ;
qw = Water flow (m³/h);
dpw = Pressure drop (kPa).

Water flow and pressure drop on heat exchanger calculated with $\Delta T= 5\text{ }^{\circ}\text{C}$.

COOLING CAPACITY PERFORMANCE

Twout			210					
			Tae					
			25°C	30°C	32°C	35°C	40°C	43°C
6°C	Pf	kW	788,9	749,5	732,7	706,2	671,6	650,8
	Pa	kW	182,0	196,2	202,6	213,0	227,5	236,6
	qw	m ³ /h	135,69	128,92	126,02	121,47	115,52	111,94
	dpw	kPa	53,6	48,4	46,2	42,9	38,8	36,5
7°C	Pf	kW	813,1	772,6	755,2	728,0	692,3	670,9
	Pa	kW	184,6	198,9	205,4	215,9	230,5	239,8
	qw	m ³ /h	139,86	132,89	129,90	125,22	119,08	115,39
	dpw	kPa	56,9	51,4	49,1	45,6	41,3	38,8
8°C	Pf	kW	837,9	796,2	778,3	750,2	713,5	691,4
	Pa	kW	187,3	201,7	208,2	218,8	233,6	242,9
	qw	m ³ /h	144,11	136,94	133,86	129,04	122,72	118,91
	dpw	kPa	60,4	54,6	52,2	48,5	43,8	41,2
9°C	Pf	kW	863,2	820,2	801,8	773,0	735,1	712,3
	Pa	kW	190,0	204,5	211,1	221,8	236,7	246,2
	qw	m ³ /h	148,47	141,08	137,91	132,95	126,44	122,52
	dpw	kPa	64,2	57,9	55,4	51,4	46,5	43,7
10°C	Pf	kW	889,0	844,8	825,9	796,2	757,2	733,7
	Pa	kW	192,8	207,4	214,0	224,8	239,9	249,5
	qw	m ³ /h	152,92	145,31	142,05	136,94	130,24	126,19
	dpw	kPa	68,1	61,5	58,7	54,6	49,4	46,4
11°C	Pf	kW	915,5	870,0	850,5	819,9	779,8	755,5
	Pa	kW	195,7	210,4	217,0	227,9	243,2	252,8
	qw	m ³ /h	157,46	149,64	146,28	141,02	134,12	129,95
	dpw	kPa	72,2	65,2	62,3	57,9	52,4	49,2

Tae= Outdoor air temperature(°C);

Twout = Outlet water temperature (°C);

Pf = Cooling capacity (kW);

Pa = Compressors power input (kW) ;

qw = Water flow (m³/h);

dpw = Pressure drop (kPa).

Water flow and pressure drop on heat exchanger calculated with $\Delta T= 5\text{ }^{\circ}\text{C}$.

MULTIPIPE CHILLER RTMA

HEATING CAPACITY PERFORMANCE

RTMA SL

Ta /R.U		105							115						
		Twout							Twout						
		30°C	35°C	40°C	45°C	55°C	65°C (1)	30°C	35°C	40°C	45°C	55°C	65°C (1)		
-5°C / 90 %	Pt kW	315,5	302,5	289,8	278,0	259,0	249,6	356,1	341,2	326,5	312,8	290,3	278,3		
	Pat kW	79,8	86,5	93,8	101,9	119,5	138,6	90,5	98,0	106,3	115,4	135,4	157,2		
	qw m³/h	54,26	52,03	49,84	47,81	44,55	42,93	61,24	58,68	56,16	53,80	49,93	47,87		
	dpw kPa	50,4	46,3	42,5	39,1	33,9	31,5	37,7	34,6	31,7	29,1	25,1	23,1		
0°C / 90 %	Pt kW	377,4	362,2	347,0	332,4	306,8	289,5	426,0	408,6	391,2	374,3	344,4	323,6		
	Pat kW	84,3	91,0	98,5	106,7	125,1	145,3	95,6	103,1	111,5	120,8	141,6	164,6		
	qw m³/h	64,91	62,30	59,69	57,17	52,77	49,80	73,27	70,29	67,29	64,39	59,24	55,65		
	dpw kPa	72,0	66,4	60,9	55,9	47,6	42,4	54,0	49,7	45,6	41,7	35,3	31,2		
7°C / 90 %	Pt kW	475,0	456,8	438,1	419,5	384,7	356,5	536,1	515,4	494,1	472,9	432,6	399,4		
	Pat kW	91,3	97,8	105,2	113,6	132,5	153,9	103,5	110,7	119,1	128,6	150,0	174,2		
	qw m³/h	81,70	78,57	75,36	72,16	66,17	61,31	92,21	88,65	84,99	81,33	74,41	68,70		
	dpw kPa	114,1	105,6	97,1	89,1	74,9	64,3	85,6	79,1	72,7	66,6	55,7	47,5		
10°C / 90 %	Pt kW	521,9	502,4	482,2	461,9	423,0	389,9	589,1	566,9	543,9	520,7	475,9	437,3		
	Pat kW	94,6	101,0	108,4	116,7	135,8	157,5	107,3	114,4	122,7	132,0	153,6	178,3		
	qw m³/h	89,77	86,41	82,94	79,44	72,76	67,07	101,32	97,51	93,55	89,55	81,85	75,21		
	dpw kPa	137,8	127,7	117,6	107,9	90,5	76,9	103,3	95,7	88,1	80,7	67,4	56,9		
15°C / 90 %	Pt kW	605,6	583,8	561,0	537,8	492,1	451,0	683,4	658,7	632,8	606,4	554,0	506,3		
	Pat kW	100,6	106,7	113,8	122,0	141,2	163,3	114,1	120,8	128,8	138,1	159,6	184,7		
	qw m³/h	104,16	100,41	96,49	92,50	84,64	77,56	117,54	113,30	108,85	104,29	95,28	87,08		
	dpw kPa	185,5	172,4	159,2	146,3	122,5	102,9	139,0	129,2	119,2	109,5	91,4	76,3		

Ta /R.U. = Outdoor air temperature (°C)/Relative humidity (%)

Twout = Outlet water temperature (°C);

Pt = Heating capacity (kW);

Pa = Compressors power input (kW) ;

qw = Water flow (m³/h);

dpw = Pressure drop (kPa).

Water flow and pressure drop on heat exchanger calculated with $\Delta T = 5$ °C.

(1) Units equipped with the accessory High Performance temperature (HPT), with outlet water temperature up to 65°C.

HEATING CAPACITY PERFORMANCE
RTMA SL

Ta /R.U		120						130					
		Twout						Twout					
		30°C	35°C	40°C	45°C	55°C	65°C (1)	30°C	35°C	40°C	45°C	55°C	65°C (1)
-5°C / 90 %	Pt kW	370,9	355,0	339,4	324,9	301,5	289,5	406,4	393,5	380,7	368,3	347,0	333,1
	Pat kW	89,0	96,4	104,7	113,6	133,3	154,6	98,3	106,5	115,7	126,1	149,8	177,6
	qw m ³ /h	63,79	61,05	58,39	55,89	51,85	49,79	69,91	67,69	65,48	63,35	59,69	57,29
	dpw kPa	38,9	35,7	32,6	29,9	25,7	23,7	43,9	41,1	38,5	36,0	32,0	29,5
0°C / 90 %	Pt kW	444,5	426,0	407,5	389,6	358,1	336,6	479,4	464,1	448,5	433,1	404,5	381,9
	Pat kW	94,0	101,5	109,8	119,1	139,6	162,1	102,9	111,1	120,5	131,2	156,0	185,3
	qw m ³ /h	76,45	73,27	70,09	67,01	61,60	57,90	82,45	79,83	77,15	74,50	69,58	65,68
	dpw kPa	55,9	51,4	47,0	43,0	36,3	32,1	61,0	57,2	53,4	49,8	43,5	38,7
7°C / 90 %	Pt kW	560,8	538,7	516,0	493,3	450,8	416,0	595,4	576,5	556,8	536,7	497,4	462,0
	Pat kW	101,8	109,1	117,4	126,8	148,0	171,9	110,5	118,4	127,8	138,5	164,2	195,1
	qw m ³ /h	96,45	92,65	88,75	84,85	77,53	71,55	102,40	99,15	95,77	92,32	85,55	79,47
	dpw kPa	89,0	82,1	75,4	68,9	57,5	49,0	94,2	88,3	82,4	76,5	65,7	56,7
10°C / 90 %	Pt kW	616,7	593,0	568,5	543,8	496,3	455,7	651,9	631,3	609,7	587,5	543,2	502,0
	Pat kW	105,5	112,6	120,9	130,2	151,6	175,9	114,3	122,0	131,3	142,0	167,8	199,3
	qw m ³ /h	106,08	102,00	97,78	93,53	85,37	78,38	112,13	108,59	104,87	101,05	93,43	86,34
	dpw kPa	107,7	99,6	91,5	83,7	69,7	58,8	112,9	105,9	98,8	91,7	78,4	66,9
15°C / 90 %	Pt kW	716,5	690,1	662,5	634,3	578,7	528,4	754,2	730,6	705,6	679,7	626,8	575,5
	Pat kW	112,2	119,0	127,0	136,2	157,7	182,5	121,5	128,8	137,7	148,3	174,1	206,1
	qw m ³ /h	123,24	118,70	113,95	109,10	99,54	90,88	129,73	125,67	121,37	116,91	107,81	98,99
	dpw kPa	145,4	134,8	124,3	113,9	94,8	79,0	151,1	141,8	132,3	122,7	104,4	88,0

Ta /R.U. = Outdoor air temperature (°C)/Relative humidity (%)

Twout = Outlet water temperature (°C);

Pt = Heating capacity (kW);

Pa = Compressors power input (kW) ;

qw = Water flow (m³/h);

dpw = Pressure drop (kPa).

 Water flow and pressure drop on heat exchanger calculated with $\Delta T = 5\text{ °C}$.

(1) Units equipped with the accessory High Performance temperature (HPT), with outlet water temperature up to 65°C.

MULTIPIPE CHILLER RTMA

HEATING CAPACITY PERFORMANCE

RTMA SL

Ta /R.U		150						170					
		Twout						Twout					
		30°C	35°C	40°C	45°C	55°C	65°C (1)	30°C	35°C	40°C	45°C	55°C	65°C (1)
-5°C / 90 %	Pt kW	456,3	445,9	435,3	424,9	406,1	391,8	521,3	509,1	496,7	484,3	461,3	442,8
	Pat kW	110,5	119,6	130,1	142,1	170,4	205,1	123,6	133,8	145,7	159,1	191,1	230,4
	qw m³/h	78,48	76,69	74,87	73,09	69,84	67,39	89,66	87,57	85,43	83,31	79,35	76,17
	dpw kPa	50,7	48,4	46,2	44,0	40,2	37,4	62,8	59,9	57,0	54,2	49,2	45,3
0°C / 90 %	Pt kW	532,7	520,2	507,1	493,8	468,0	445,3	608,0	593,3	577,9	562,2	531,2	503,1
	Pat kW	114,8	124,0	134,8	147,1	176,9	213,7	128,6	138,8	150,9	164,7	198,2	239,6
	qw m³/h	91,63	89,47	87,22	84,93	80,49	76,59	104,58	102,05	99,40	96,70	91,36	86,53
	dpw kPa	69,1	65,9	62,6	59,4	53,4	48,3	85,4	81,3	77,1	73,0	65,2	58,5
7°C / 90 %	Pt kW	655,5	639,3	622,0	604,0	567,1	531,3	747,3	728,3	708,0	686,9	643,3	600,4
	Pat kW	122,1	131,1	141,8	154,4	185,4	224,3	137,2	147,1	159,0	173,0	207,6	251,2
	qw m³/h	112,75	109,95	106,98	103,88	97,55	91,39	128,54	125,27	121,78	118,14	110,65	103,26
	dpw kPa	104,7	99,5	94,2	88,9	78,4	68,8	129,0	122,5	115,8	109,0	95,6	83,2
10°C / 90 %	Pt kW	716,2	698,1	678,7	658,4	616,3	574,2	816,2	795,0	772,3	748,5	698,9	648,9
	Pat kW	126,0	134,8	145,4	158,0	189,2	228,8	141,8	151,4	163,1	177,1	211,9	256,2
	qw m³/h	123,19	120,08	116,74	113,25	106,00	98,77	140,39	136,74	132,84	128,75	120,21	111,62
	dpw kPa	125,0	118,7	112,2	105,6	92,5	80,3	153,9	146,0	137,8	129,4	112,8	97,3
15°C / 90 %	Pt kW	827,7	806,2	783,0	758,4	706,7	653,7	942,6	917,4	890,3	861,7	801,3	738,9
	Pat kW	133,8	142,0	152,2	164,6	195,9	236,3	151,0	159,9	171,1	184,8	219,6	264,6
	qw m³/h	142,37	138,66	134,67	130,45	121,56	112,43	162,12	157,79	153,14	148,22	137,82	127,09
	dpw kPa	166,9	158,3	149,3	140,1	121,7	104,1	205,2	194,4	183,1	171,5	148,3	126,1

Ta /R.U. = Outdoor air temperature (°C)/Relative humidity (%)

Twout = Outlet water temperature (°C);

Pt = Heating capacity (kW);

Pa = Compressors power input (kW) ;

qw = Water flow (m³/h);

dpw = Pressure drop (kPa).

Water flow and pressure drop on heat exchanger calculated with $\Delta T = 5$ °C.

(1) Units equipped with the accessory High Performance temperature (HPT), with outlet water temperature up to 65°C.

HEATING CAPACITY PERFORMANCE
RTMA SL

Ta /R.U		180						190					
		Twout						Twout					
		30°C	35°C	40°C	45°C	55°C	65°C (1)	30°C	35°C	40°C	45°C	55°C	65°C (1)
-5°C / 90 %	Pt kW	536,6	524,2	511,7	499,6	477,9	462,1	553,0	540,2	527,2	514,3	490,4	471,5
	Pat kW	131,6	142,6	155,2	169,4	203,1	244,2	139,3	150,8	164,1	179,2	215,1	259,1
	qw m ³ /h	92,29	90,16	88,01	85,93	82,19	79,48	95,11	92,92	90,68	88,47	84,35	81,10
	dpw kPa	64,5	61,6	58,7	55,9	51,2	47,9	26,8	25,6	24,4	23,2	21,1	19,5
0°C / 90 %	Pt kW	626,9	612,0	596,6	581,0	550,9	525,0	645,2	629,8	613,7	597,2	564,9	535,9
	Pat kW	136,6	147,8	160,7	175,5	211,1	254,8	144,9	156,4	169,9	185,5	223,1	269,6
	qw m ³ /h	107,83	105,27	102,61	99,93	94,76	90,30	110,97	108,32	105,55	102,73	97,17	92,17
	dpw kPa	88,1	83,9	79,7	75,6	68,0	61,8	36,5	34,8	33,1	31,3	28,0	25,2
7°C / 90 %	Pt kW	772,1	752,8	732,3	711,1	667,8	626,2	793,2	773,4	752,1	730,0	684,4	639,7
	Pat kW	145,0	155,9	169,0	184,1	221,3	267,8	154,5	165,6	179,0	194,8	233,7	282,8
	qw m ³ /h	132,80	129,48	125,96	122,30	114,86	107,70	136,44	133,02	129,37	125,56	117,72	110,03
	dpw kPa	133,6	127,0	120,2	113,3	99,9	87,9	55,2	52,5	49,7	46,8	41,1	35,9
10°C / 90 %	Pt kW	843,9	822,4	799,4	775,4	725,7	676,6	866,5	844,3	820,6	795,6	743,7	691,5
	Pat kW	149,5	160,2	173,1	188,3	225,8	273,2	159,7	170,5	183,7	199,4	238,5	288,4
	qw m ³ /h	145,15	141,45	137,50	133,36	124,82	116,37	149,03	145,22	141,14	136,85	127,91	118,93
	dpw kPa	159,6	151,5	143,2	134,7	118,0	102,6	65,9	62,6	59,1	55,6	48,5	42,0
15°C / 90 %	Pt kW	975,8	950,1	922,5	893,5	832,3	770,0	1000,8	974,5	946,2	916,1	852,7	787,4
	Pat kW	158,3	168,4	180,9	195,9	233,6	282,1	169,9	180,0	192,6	208,0	247,1	297,8
	qw m ³ /h	167,83	163,42	158,68	153,68	143,16	132,43	172,14	167,62	162,74	157,58	146,67	135,43
	dpw kPa	213,4	202,3	190,7	178,9	155,2	132,8	87,9	83,3	78,6	73,7	63,8	54,4

Ta /R.U. = Outdoor air temperature (°C)/Relative humidity (%)

Twout = Outlet water temperature (°C);

Pt = Heating capacity (kW);

Pa = Compressors power input (kW) ;

qw = Water flow (m³/h);

dpw = Pressure drop (kPa).

Water flow and pressure drop on heat exchanger calculated with $\Delta T = 5\text{ °C}$.

(1) Units equipped with the accessory High Performance temperature (HPT), with outlet water temperature up to 65°C.

MULTIPIPE CHILLER RTMA

HEATING CAPACITY PERFORMANCE

RTMA SL

Ta /R.U			210					
			Twout					
			30°C	35°C	40°C	45°C	55°C	65°C (1)
-5°C / 90 %	Pt	kW	625,2	610,8	596,1	581,5	554,5	533,1
	Pat	kW	152,2	164,7	179,2	195,7	235,0	283,0
	qw	m³/h	107,54	105,06	102,53	100,02	95,37	91,69
	dpw	kPa	33,7	32,1	30,6	29,1	26,5	24,5
0°C / 90 %	Pt	kW	716,9	699,9	682,1	664,0	628,7	597,1
	Pat	kW	157,5	170,1	184,9	201,8	242,7	293,2
	qw	m³/h	124,13	121,44	118,60	115,67	109,92	104,79
	dpw	kPa	44,8	42,9	40,9	38,9	35,2	32,0
7°C / 90 %	Pt	kW	896,9	874,4	850,4	825,4	773,8	723,3
	Pat	kW	168,7	180,9	195,6	212,8	255,3	308,9
	qw	m³/h	154,26	150,39	146,27	141,96	133,10	124,40
	dpw	kPa	69,3	65,8	62,3	58,7	51,6	45,0
10°C / 90 %	Pt	kW	979,6	954,6	927,8	899,5	840,8	781,8
	Pat	kW	174,4	186,2	200,6	217,8	260,5	315,0
	qw	m³/h	168,50	164,19	159,57	154,72	144,62	134,47
	dpw	kPa	82,6	78,5	74,1	69,7	60,9	52,6
15°C / 90 %	Pt	kW	1131,6	1101,8	1069,7	1035,8	964,1	890,2
	Pat	kW	185,6	196,6	210,4	227,2	269,9	325,3
	qw	m³/h	194,63	189,51	184,00	178,16	165,83	153,12
	dpw	kPa	110,3	104,5	98,5	92,4	80,0	68,2

Ta /R.U. = Outdoor air temperature (°C)/Relative humidity (%)

Twout = Outlet water temperature (°C);

Pt = Heating capacity (kW);

Pa = Compressors power input (kW) ;

qw = Water flow (m³/h);

dpw = Pressure drop (kPa).

Water flow and pressure drop on heat exchanger calculated with $\Delta T = 5^\circ\text{C}$.

(1) Units equipped with the accessory High Performance temperature (HPT), with outlet water temperature up to 65°C.

RECOVERY CAPACITY PERFORMANCE

RTMA SL

Twout			105						115					
			Twoutr						Twoutr					
			30°C	35°C	40°C	45°C	55°C	65°C (1)	30°C	35°C	40°C	45°C	55°C	65°C (1)
6°C	Pf	kW	438,6	411,6	383,2	354,1	325,1	296,9	485,2	455,7	424,3	391,8	359,0	326,7
	Pa	kW	89,9	96,5	104,0	112,5	121,7	131,6	101,5	108,6	116,8	126,1	136,2	147,2
	qw	m³/h	75,45	70,80	65,91	60,91	55,92	51,07	83,46	78,38	72,98	67,40	61,75	56,19
	dpw	kPa	97,3	85,7	74,3	63,4	53,5	44,6	70,1	61,8	53,6	45,7	38,4	31,8
	Pr	kW	528,5	508,1	487,2	466,6	446,8	428,5	586,8	564,3	541,2	517,9	495,3	473,8
	qwr	m³/h	90,90	87,39	83,80	80,25	76,85	73,70	100,93	97,07	93,08	89,08	85,18	81,50
	dpwr	kPa	141,3	130,6	120,1	110,1	101,0	92,9	102,5	94,8	87,2	79,8	73,0	66,8
7°C	Pf	kW	455,0	427,5	398,5	368,7	338,9	309,8	502,7	472,7	440,8	407,7	374,0	340,8
	Pa	kW	90,9	97,5	105,0	113,5	122,7	132,7	102,8	109,8	118,0	127,2	137,4	148,3
	qw	m³/h	78,26	73,52	68,54	63,42	58,29	53,29	86,47	81,31	75,81	70,12	64,33	58,61
	dpw	kPa	104,7	92,4	80,3	68,8	58,1	48,6	75,2	66,5	57,8	49,5	41,6	34,6
	Pr	kW	545,9	524,9	503,5	482,2	461,7	442,5	605,5	582,5	558,7	534,9	511,4	489,1
	qwr	m³/h	93,89	90,29	86,60	82,94	79,41	76,11	104,15	100,19	96,10	92,00	87,96	84,13
	dpwr	kPa	150,8	139,4	128,3	117,6	107,8	99,1	109,1	101,0	92,9	85,2	77,8	71,2
8°C	Pf	kW	471,6	443,7	414,1	383,6	353,1	323,1	520,6	490,1	457,6	423,7	389,4	355,2
	Pa	kW	92,0	98,5	106,1	114,5	123,8	133,8	104,0	111,0	119,1	128,3	138,5	149,5
	qw	m³/h	81,12	76,31	71,22	65,99	60,73	55,58	89,54	84,30	78,70	72,88	66,97	61,10
	dpw	kPa	112,5	99,6	86,7	74,5	63,1	52,8	80,7	71,5	62,3	53,4	45,1	37,6
	Pr	kW	563,6	542,2	520,1	498,2	476,9	456,9	624,6	601,1	576,7	552,1	527,9	504,7
	qwr	m³/h	96,94	93,25	89,47	85,68	82,02	78,59	107,43	103,38	99,19	94,95	90,79	86,82
	dpwr	kPa	160,7	148,7	136,9	125,6	115,1	105,6	116,1	107,5	99,0	90,7	82,9	75,8
9°C	Pf	kW	488,7	460,2	430,0	398,9	367,6	336,8	538,8	507,8	474,7	440,2	405,1	370,0
	Pa	kW	93,1	99,6	107,1	115,6	124,8	134,9	105,3	112,2	120,3	129,5	139,7	150,7
	qw	m³/h	84,05	79,15	73,97	68,62	63,23	57,93	92,67	87,34	81,65	75,71	69,67	63,65
	dpw	kPa	120,8	107,1	93,6	80,5	68,4	57,4	86,4	76,8	67,1	57,7	48,8	40,8
	Pr	kW	581,7	559,8	537,1	514,5	492,4	471,7	644,0	620,0	595,0	569,7	544,7	520,7
	qwr	m³/h	100,06	96,28	92,39	88,49	84,70	81,12	110,77	106,64	102,34	97,98	93,69	89,57
	dpwr	kPa	171,2	158,5	146,0	133,9	122,7	112,5	123,5	114,4	105,4	96,6	88,3	80,7
10°C	Pf	kW	506,0	477,1	446,3	414,6	382,5	350,8	557,3	525,9	492,2	457,0	421,1	385,2
	Pa	kW	94,2	100,7	108,2	116,6	125,9	136,0	106,5	113,4	121,5	130,6	140,8	151,9
	qw	m³/h	87,03	82,06	76,77	71,31	65,79	60,34	95,86	90,45	84,66	78,61	72,43	66,26
	dpw	kPa	129,5	115,1	100,8	87,0	74,0	62,3	92,5	82,3	72,1	62,2	52,8	44,2
	Pr	kW	600,2	577,7	554,5	531,2	508,4	486,8	663,8	639,3	613,7	587,7	561,9	537,1
	qwr	m³/h	103,23	99,37	95,37	91,36	87,44	83,72	114,18	109,96	105,55	101,08	96,65	92,38
	dpwr	kPa	182,3	168,9	155,6	142,7	130,8	119,9	131,2	121,7	112,1	102,8	94,0	85,9
11°C	Pf	kW	523,7	494,3	463,0	430,6	397,7	365,2	576,2	544,3	510,0	474,2	437,5	400,7
	Pa	kW	95,3	101,7	109,2	117,7	127,0	137,0	107,9	114,7	122,7	131,8	142,0	153,1
	qw	m³/h	90,08	85,02	79,64	74,06	68,40	62,81	99,10	93,62	87,73	81,56	75,25	68,93
	dpw	kPa	138,8	123,6	108,5	93,8	80,0	67,5	98,8	88,2	77,4	66,9	57,0	47,8
	Pr	kW	619,0	596,0	572,2	548,2	524,7	502,2	684,0	658,9	632,7	606,0	579,5	553,8
	qwr	m³/h	106,47	102,52	98,42	94,29	90,24	86,38	117,65	113,34	108,82	104,23	99,67	95,25
	dpwr	kPa	193,9	179,7	165,7	152,0	139,3	127,6	139,3	129,3	119,2	109,3	100,0	91,3

Twout = Outlet water temperature (°C);
Twoutr = Heating side heat exchanger leaving water temperature (°C)
Pf = Cooling capacity (kW);
Pr = Recovery mode heating capacity (kW);
Pa = Compressors heating capacity (kW);
qw = Water flow (m³/h);
dpw = Pressure drop (kPa);
qwr = Recovery heat exchanger water flow (m³/h);
dpwr = Recovery heat exchanger pressure drop (kPa).

Water flow and pressure drop on heat exchanger calculated with $\Delta T = 5^\circ\text{C}$

(1) Units equipped with the accessory High Performance temperature (HPT), with outlet water temperature up to 65°C.

MULTIPIPE CHILLER RTMA

RECOVERY CAPACITY PERFORMANCE

RTMA SL

Twout			120						130					
			Twoutr						Twoutr					
			30°C	35°C	40°C	45°C	55°C	65°C (1)	30°C	35°C	40°C	45°C	55°C	65°C (1)
6°C	Pf	kW	506,1	475,4	442,9	409,5	375,9	343,0	537,3	508,9	478,4	446,4	413,6	380,4
	Pa	kW	98,5	105,5	113,6	122,7	132,6	143,3	107,5	115,7	125,2	136,0	148,2	161,6
	qw	m³/h	87,05	81,77	76,18	70,43	64,65	58,99	92,41	87,52	82,28	76,79	71,14	65,44
	dpw	kPa	72,5	64,0	55,5	47,5	40,0	33,3	76,7	68,8	60,8	52,9	45,4	38,4
	Pr	kW	604,6	580,9	556,5	532,2	508,5	486,3	644,8	624,6	603,6	582,5	561,8	542,0
	qwr	m³/h	103,99	99,92	95,72	91,53	87,47	83,65	110,91	107,42	103,82	100,18	96,62	93,23
	dpwr	kPa	103,5	95,5	87,7	80,2	73,2	67,0	110,5	103,6	96,8	90,1	83,8	78,0
7°C	Pf	kW	524,5	493,3	460,2	426,0	391,6	357,7	556,4	527,4	496,3	463,5	429,7	395,5
	Pa	kW	99,7	106,6	114,7	132,9	133,8	144,5	108,6	116,8	126,3	137,1	149,3	162,8
	qw	m³/h	90,22	84,84	79,15	73,27	67,35	61,53	95,70	90,72	85,36	79,72	73,91	68,03
	dpw	kPa	77,9	68,9	60,0	51,4	43,4	36,2	82,2	73,9	65,4	57,1	49,1	41,6
	Pr	kW	624,2	599,9	574,9	558,9	525,3	502,2	665,1	644,2	622,5	600,6	579,0	558,3
	qwr	m³/h	107,36	103,19	98,88	96,13	90,36	86,38	114,39	110,80	107,07	103,30	99,59	96,03
	dpwr	kPa	110,3	101,9	93,6	88,4	78,1	71,4	117,5	110,2	102,9	95,8	89,1	82,8
8°C	Pf	kW	543,3	511,5	477,8	442,9	407,6	372,8	576,0	546,4	514,6	481,0	446,3	411,1
	Pa	kW	100,9	107,8	115,8	124,9	134,9	145,7	109,8	117,8	127,3	138,2	150,4	163,9
	qw	m³/h	93,45	87,98	82,18	76,18	70,11	64,13	99,08	93,99	88,51	82,73	76,76	70,70
	dpw	kPa	83,6	74,1	64,6	55,5	47,0	39,4	88,1	79,3	70,3	61,5	52,9	44,9
	Pr	kW	644,1	619,3	593,6	567,8	542,5	518,5	685,8	664,3	641,9	619,2	596,7	575,0
	qwr	m³/h	110,79	106,52	102,11	97,66	93,32	89,18	117,96	114,26	110,41	106,50	102,63	98,90
	dpwr	kPa	117,5	108,6	99,8	91,3	83,3	76,1	124,9	117,2	109,5	101,8	94,6	87,8
9°C	Pf	kW	562,4	530,2	495,8	460,2	424,1	388,3	596,1	565,9	533,3	498,9	463,3	427,0
	Pa	kW	102,1	109,0	117,0	126,0	136,0	146,9	111,0	119,0	128,4	139,3	151,5	165,1
	qw	m³/h	96,74	91,19	85,28	79,15	72,94	66,79	102,52	97,33	91,73	85,82	79,69	73,45
	dpw	kPa	89,6	79,6	69,6	60,0	50,9	42,7	94,4	85,1	75,6	66,1	57,0	48,4
	Pr	kW	664,5	639,1	612,8	586,2	560,1	535,2	707,0	684,9	661,8	638,2	614,8	592,2
	qwr	m³/h	114,29	109,93	105,40	100,83	96,34	92,05	121,61	117,80	113,82	109,78	105,75	101,85
	dpwr	kPa	125,0	115,6	106,3	97,3	88,8	81,1	132,8	124,6	116,3	108,2	100,4	93,1
10°C	Pf	kW	581,9	549,2	514,2	477,8	440,9	404,2	616,6	585,8	552,5	517,3	480,8	443,4
	Pa	kW	103,3	110,2	118,1	127,2	137,2	148,0	112,2	120,1	129,5	140,4	152,7	166,3
	qw	m³/h	100,09	94,45	88,44	82,19	75,83	69,52	106,05	100,76	95,04	88,98	82,69	76,27
	dpw	kPa	95,9	85,4	74,9	64,6	55,0	46,3	101,0	91,2	81,1	71,1	61,4	52,2
	Pr	kW	685,3	659,3	632,3	605,0	578,1	552,2	728,7	705,9	682,1	657,7	633,4	609,8
	qwr	m³/h	82,23	79,12	75,88	72,60	69,37	66,27	87,45	84,71	81,85	78,93	76,01	73,17
	dpwr	kPa	64,7	59,9	55,1	50,4	46,1	42,0	68,7	64,4	60,2	55,9	51,9	48,1
11°C	Pf	kW	601,8	568,5	532,9	495,9	458,1	420,5	637,6	606,2	572,2	536,2	498,7	460,3
	Pa	kW	104,6	111,4	119,3	128,3	138,3	149,2	113,4	121,3	130,7	141,5	153,8	167,5
	qw	m³/h	103,51	97,79	91,67	85,29	78,79	72,32	109,66	104,27	98,42	92,22	85,77	79,16
	dpw	kPa	102,5	91,5	80,4	69,6	59,4	50,1	108,0	97,6	87,0	76,4	66,1	56,3
	Pr	kW	706,4	679,9	652,3	624,2	596,4	569,7	751,0	727,5	702,9	677,7	652,5	627,8
	qwr	m³/h	121,50	116,94	112,19	107,36	102,59	97,98	129,17	125,13	120,90	116,57	112,23	107,98
	dpwr	kPa	141,3	130,9	120,4	110,3	100,7	91,9	149,8	140,6	131,2	122,0	113,1	104,7

Twout = Outlet water temperature (°C);
 Twoutr = Heating side heat exchanger leaving water temperature (°C)
 Pf = Cooling capacity (kW);
 Pr = Recovery mode heating capacity (kW);
 Pa = Compressors heating capacity (kW);
 qw = Water flow (m³/h);
 dpw = Pressure drop (kPa);
 qwr = Recovery heat exchanger water flow (m³/h);
 dpw = Recovery heat exchanger pressure drop (kPa).

Water flow and pressure drop on heat exchanger calculated with $\Delta T = 5^\circ\text{C}$

(1) Units equipped with the accessory High Performance temperature (HPT), with outlet water temperature up to 65°C.

RECOVERY CAPACITY PERFORMANCE

RTMA SL

Twout		150							170					
		Twoutr							Twoutr					
		30°C	35°C	40°C	45°C	55°C	65°C (1)	30°C	35°C	40°C	45°C	55°C	65°C (1)	
6°C	Pf	kW	599,1	572,6	543,1	511,1	476,7	440,2	671,1	641,7	609,2	573,9	536,2	496,4
	Pa	kW	122,7	131,6	142,4	155,0	169,5	186,0	132,2	142,1	153,9	167,6	183,4	201,3
	qw	m³/h	103,04	98,48	93,42	87,90	81,99	75,72	115,43	110,38	104,78	98,71	92,22	85,38
	dpw	kPa	87,4	79,9	71,9	63,6	55,3	47,2	104,0	95,1	85,7	76,1	66,4	56,9
	Pr	kW	721,7	704,2	685,5	666,0	646,1	626,2	803,3	783,8	763,0	741,5	719,5	697,6
	qwr	m³/h	124,13	121,12	117,91	114,56	111,14	107,71	138,17	134,81	131,24	127,54	123,76	119,99
	dpwr	kPa	126,9	120,8	114,5	108,1	101,7	95,5	149,1	141,9	134,5	127,0	119,6	112,4
7°C	Pf	kW	619,3	592,2	562,1	529,2	493,9	456,4	693,8	663,8	630,4	594,2	555,4	514,5
	Pa	kW	123,9	132,8	143,5	156,1	170,6	187,2	133,5	143,3	155,0	168,8	184,6	202,6
	qw	m³/h	106,51	101,86	96,68	91,02	84,95	78,50	119,33	114,17	108,43	102,20	95,53	88,49
	dpw	kPa	93,4	85,4	77,0	68,2	59,4	50,7	111,2	101,8	91,8	81,5	71,2	61,1
	Pr	kW	743,1	725,0	705,6	685,3	664,5	643,6	827,3	807,0	785,5	763,0	740,0	717,0
	qwr	m³/h	127,82	124,70	121,36	117,87	114,30	110,70	142,29	138,81	135,10	131,24	127,29	123,33
	dpwr	kPa	134,5	128,0	121,3	114,4	107,6	100,9	158,1	150,4	142,5	134,5	126,5	118,7
8°C	Pf	kW	640,0	612,3	581,5	547,8	511,5	473,0	717,1	686,3	652,2	615,1	575,2	533,0
	Pa	kW	125,2	134,0	144,7	157,3	171,8	188,4	134,8	144,5	156,3	170,0	185,9	203,9
	qw	m³/h	110,08	105,32	100,02	94,22	87,99	81,36	123,33	118,05	112,18	105,79	98,93	91,68
	dpw	kPa	99,8	91,3	82,4	73,1	63,7	54,5	118,8	108,8	98,3	87,4	76,4	65,6
	Pr	kW	765,1	746,3	726,2	705,1	683,4	661,5	851,9	830,9	808,5	785,1	761,1	737,0
	qwr	m³/h	131,61	128,37	124,90	121,27	117,54	113,77	146,52	142,91	139,06	135,03	130,91	126,76
	dpwr	kPa	142,6	135,7	128,5	121,1	113,8	106,6	167,6	159,4	151,0	142,4	133,8	125,4
9°C	Pf	kW	661,2	633,0	601,5	566,9	529,7	490,1	740,9	709,5	674,6	636,5	595,5	552,1
	Pa	kW	126,5	135,2	145,9	158,4	173,0	189,7	136,2	145,8	157,5	171,3	187,2	205,3
	qw	m³/h	113,73	108,87	103,45	97,51	91,11	84,30	127,43	122,04	116,03	109,47	102,43	94,97
	dpw	kPa	106,5	97,6	88,1	78,3	68,3	58,5	126,8	116,3	105,1	93,6	81,9	70,4
	Pr	kW	787,7	768,2	747,3	725,4	702,7	679,8	877,1	855,3	832,1	807,7	782,7	757,4
	qwr	m³/h	135,49	132,13	128,54	124,76	120,87	116,93	150,86	147,12	143,12	138,93	134,63	130,28
	dpwr	kPa	151,2	143,8	136,0	128,2	120,3	112,6	177,7	169,0	159,9	150,7	141,5	132,5
10°C	Pf	kW	683,0	654,2	621,9	586,5	548,3	507,7	765,3	733,3	697,5	658,4	616,4	571,8
	Pa	kW	127,9	136,5	147,1	159,7	174,3	191,0	137,7	147,2	158,8	172,6	188,5	206,7
	qw	m³/h	117,47	112,52	106,97	100,88	94,31	87,32	131,64	126,12	119,97	113,25	106,02	98,35
	dpw	kPa	113,6	104,2	94,2	83,8	73,2	62,8	135,3	124,2	112,4	100,1	87,8	75,5
	Pr	kW	810,9	790,7	769,0	746,2	722,6	698,6	903,0	880,5	856,3	831,0	804,9	778,4
	qwr	m³/h	97,31	94,88	92,28	89,54	86,71	83,84	108,36	105,66	102,76	99,72	96,59	93,41
	dpwr	kPa	78,0	74,1	70,1	66,0	61,9	57,9	91,7	87,2	82,4	77,6	72,8	68,1
11°C	Pf	kW	705,3	675,9	642,9	606,6	567,5	525,7	790,4	757,6	721,0	681,0	637,8	592,0
	Pa	kW	129,4	137,9	148,4	160,9	175,5	192,3	139,2	148,6	160,2	173,9	189,8	208,1
	qw	m³/h	121,31	116,25	110,57	104,34	97,61	90,42	135,95	130,31	124,02	117,13	109,71	101,82
	dpw	kPa	121,2	111,3	100,7	89,6	78,4	67,3	144,3	132,6	120,1	107,1	94,0	80,9
	Pr	kW	834,7	813,8	791,3	767,6	743,0	718,0	929,6	906,2	881,2	854,9	827,7	800,0
	qwr	m³/h	143,57	139,97	136,10	132,02	127,80	123,50	159,89	155,87	151,57	147,04	142,36	137,61
	dpwr	kPa	169,7	161,3	152,5	143,5	134,5	125,6	199,6	189,7	179,3	168,8	158,2	147,8

Twout = Outlet water temperature (°C);
Twoutr = Heating side heat exchanger leaving water temperature (°C)
Pf = Cooling capacity (kW);
Pr = Recovery mode heating capacity (kW);
Pa = Compressors heating capacity (kW);
qw = Water flow (m³/h);
dpw = Pressure drop (kPa);
qwr = Recovery heat exchanger water flow (m³/h);
dpwr = Recovery heat exchanger pressure drop (kPa).

Water flow and pressure drop on heat exchanger calculated with $\Delta T = 5^\circ\text{C}$

(1) Units equipped with the accessory High Performance temperature (HPT), with outlet water temperature up to 65°C.

MULTIPIPE CHILLER RTMA

RECOVERY CAPACITY PERFORMANCE

RTMA SL

Twout			180						190					
			Twoutr						Twoutr					
			30°C	35°C	40°C	45°C	55°C	65°C (1)	30°C	35°C	40°C	45°C	55°C	65°C (1)
6°C	Pf	kW	708,5	677,0	642,2	604,6	564,5	522,4	753,7	720,6	683,8	643,6	600,4	554,7
	Pa	kW	142,5	153,3	166,2	181,1	198,3	217,6	152,2	163,2	176,4	192,0	209,9	230,3
	qw	m³/h	121,86	116,44	110,46	103,99	97,09	89,84	129,64	123,95	117,61	110,70	103,27	95,40
	dpw	kPa	112,5	102,7	92,4	81,9	71,4	61,1	49,9	45,6	41,0	36,4	31,6	27,0
	Pr	kW	850,9	830,3	808,4	785,7	762,8	740,0	905,9	883,8	860,2	835,6	810,3	785,0
	qwr	m³/h	146,36	142,80	139,04	135,14	131,20	127,27	155,82	152,02	147,96	143,72	139,38	135,01
	dpwr	kPa	162,2	154,5	146,4	138,3	130,4	122,7	72,0	68,6	64,9	61,3	57,6	54,1
7°C	Pf	kW	732,6	700,4	664,8	626,2	585,0	541,5	779,0	745,2	707,5	666,3	622,0	574,9
	Pa	kW	143,8	154,5	167,4	182,4	199,6	219,1	153,8	164,7	177,9	193,4	211,4	231,8
	qw	m³/h	126,01	120,47	114,35	107,71	100,61	93,14	133,99	128,18	121,69	114,60	106,98	98,89
	dpw	kPa	120,3	109,9	99,0	87,9	76,7	65,7	53,3	48,7	43,9	39,0	34,0	29,0
	Pr	kW	876,4	855,0	832,2	808,6	784,6	760,6	932,8	909,9	885,4	859,7	833,3	806,8
	qwr	m³/h	150,74	147,05	143,14	139,08	134,95	130,82	160,44	156,50	152,28	147,87	143,34	138,76
	dpwr	kPa	172,1	163,8	155,2	146,5	137,9	129,6	76,4	72,7	68,8	64,9	61,0	57,1
8°C	Pf	kW	757,4	724,5	688,0	648,4	606,0	561,2	805,0	770,4	731,8	689,6	644,1	595,8
	Pa	kW	145,1	155,8	168,7	183,7	200,9	220,5	155,4	166,2	179,3	194,8	212,8	233,4
	qw	m³/h	130,27	124,61	118,34	111,52	104,23	96,53	138,45	132,51	125,88	118,61	110,79	102,48
	dpw	kPa	128,5	117,6	106,1	94,2	82,3	70,6	56,9	52,1	47,0	41,7	36,4	31,2
	Pr	kW	902,5	880,3	856,7	832,1	806,9	781,8	960,4	936,6	911,2	884,5	857,0	829,1
	qwr	m³/h	155,24	151,42	147,35	143,12	138,79	134,46	165,18	161,10	156,72	152,13	147,40	142,61
	dpwr	kPa	182,5	173,7	164,5	155,1	145,9	136,9	80,9	77,0	72,9	68,7	64,5	60,3
9°C	Pf	kW	782,8	749,2	711,8	671,2	627,6	581,5	831,6	796,3	756,8	713,6	666,9	617,2
	Pa	kW	146,6	157,2	170,0	185,0	202,3	222,0	157,1	167,8	180,8	196,3	214,3	234,9
	qw	m³/h	134,64	128,86	122,43	115,44	107,95	100,02	143,03	136,96	130,17	122,73	114,71	106,16
	dpw	kPa	137,3	125,8	113,5	100,9	88,3	75,8	60,7	55,6	50,3	44,7	39,0	33,4
	Pr	kW	929,4	906,4	881,8	856,2	829,9	803,5	988,7	964,1	937,7	909,9	881,2	852,1
	qwr	m³/h	159,85	155,89	151,67	147,26	142,74	138,20	170,05	165,82	161,28	156,50	151,57	146,57
	dpwr	kPa	193,5	184,1	174,2	164,3	154,3	144,7	85,8	81,6	77,2	72,7	68,2	63,7
10°C	Pf	kW	808,9	774,5	736,2	694,5	649,8	602,4	858,8	822,8	782,4	738,1	690,3	639,2
	Pa	kW	148,1	158,6	171,4	186,4	203,7	223,4	158,9	169,4	182,4	197,9	215,9	236,5
	qw	m³/h	139,12	133,21	126,63	119,46	111,76	103,61	147,72	141,52	134,58	126,96	118,72	109,95
	dpw	kPa	146,6	134,4	121,5	108,1	94,6	81,3	64,7	59,4	53,7	47,8	41,8	35,9
	Pr	kW	956,9	933,1	907,6	880,9	853,5	825,8	1017,7	992,2	964,8	936,0	906,1	875,8
	qwr	m³/h	164,59	160,49	156,11	151,52	146,80	142,04	175,04	170,66	165,95	160,99	155,86	150,63
	dpwr	kPa	205,2	195,1	184,6	173,9	163,2	152,8	90,9	86,4	81,7	76,9	72,1	67,3
11°C	Pf	kW	835,6	800,4	761,3	718,5	672,6	623,8	886,7	849,9	808,7	763,3	714,2	661,9
	Pa	kW	149,6	160,1	172,8	187,8	205,1	224,9	160,8	171,2	184,1	199,5	217,5	238,1
	qw	m³/h	143,72	137,67	130,94	123,59	115,68	107,30	152,52	146,19	139,09	131,29	122,85	113,84
	dpw	kPa	156,4	143,6	129,9	115,7	101,4	87,2	69,0	63,4	57,4	51,1	44,8	38,4
	Pr	kW	985,2	960,5	934,0	906,3	877,7	848,7	1047,5	1021,1	992,7	962,8	931,7	900,0
	qwr	m³/h	169,46	165,21	160,66	155,88	150,96	145,98	180,17	175,63	170,75	165,60	160,26	154,80
	dpwr	kPa	217,5	206,7	195,5	184,1	172,6	161,4	96,3	91,5	86,5	81,4	76,2	71,1

- Twout** = Outlet water temperature (°C);
- Twoutr** = Heating side heat exchanger leaving water temperature (°C)
- Pf** = Cooling capacity (kW);
- Pr** = Recovery mode heating capacity (kW);
- Pa** = Compressors heating capacity (kW) ;
- qw** = Water flow (m³/h);
- dpw** = Pressure drop (kPa);
- qwr** = Recovery heat exchanger water flow (m³/h);
- dpwr** = Recovery heat exchanger pressure drop (kPa).

Water flow and pressure drop on heat exchanger calculated with $\Delta T = 5^\circ\text{C}$

(1) Units equipped with the accessory High Performance temperature (HPT), with outlet water temperature up to 65°C.

RECOVERY CAPACITY PERFORMANCE

Twout			210					
			Twoutr					
			30°C	35°C	40°C	45°C	55°C	65°C (1)
6°C	Pf	kW	830,1	793,5	752,8	708,4	660,6	610,1
	Pa	kW	168,8	181,0	195,7	212,9	232,8	255,4
	qw	m³/h	142,77	136,48	129,48	121,84	113,63	104,93
	dpw	kPa	59,3	54,2	48,8	43,2	37,6	32,0
	Pr	kW	998,9	974,5	948,5	921,3	893,5	865,5
	qwr	m³/h	171,81	167,61	163,14	158,46	153,68	148,86
	dpwr	kPa	85,9	81,8	77,5	73,1	68,7	64,5
7°C	Pf	kW	858,0	820,6	778,9	733,0	684,4	632,4
	Pa	kW	170,5	182,6	197,3	214,0	234,4	257,1
	qw	m³/h	147,57	141,14	133,98	126,08	117,72	108,78
	dpw	kPa	63,4	58,0	52,2	46,3	40,3	34,4
	Pr	kW	1028,5	1003,2	976,2	947,0	918,8	889,5
	qwr	m³/h	176,90	172,55	167,91	162,88	158,04	153,00
	dpwr	kPa	91,1	86,7	82,1	77,2	72,7	68,1
8°C	Pf	kW	886,5	848,4	805,8	759,1	708,8	655,4
	Pa	kW	172,4	184,3	198,9	216,1	236,1	258,8
	qw	m³/h	152,48	145,92	138,59	130,57	121,92	112,73
	dpw	kPa	67,7	62,0	55,9	49,6	43,3	37,0
	Pr	kW	1058,9	1032,7	1004,6	975,2	944,9	914,2
	qwr	m³/h	182,13	177,62	172,80	167,74	162,52	157,24
	dpwr	kPa	96,5	91,8	86,9	81,9	76,9	72,0
9°C	Pf	kW	915,8	876,9	833,3	785,5	733,9	679,0
	Pa	kW	174,2	186,1	200,6	217,8	237,7	260,6
	qw	m³/h	157,52	150,82	143,32	135,10	126,23	116,79
	dpw	kPa	72,2	66,2	59,8	53,1	46,4	39,7
	Pr	kW	1090,1	1063,0	1033,8	1003,2	971,6	939,6
	qwr	m³/h	187,49	182,83	177,82	172,56	167,12	161,60
	dpwr	kPa	102,3	97,3	92,0	86,7	81,3	76,0
10°C	Pf	kW	945,9	906,1	861,5	812,6	759,7	703,3
	Pa	kW	176,2	187,9	202,3	219,5	239,4	262,3
	qw	m³/h	162,69	155,85	148,18	139,76	130,66	120,96
	dpw	kPa	77,0	70,7	63,9	56,9	49,7	42,6
	Pr	kW	1122,1	1094,0	1063,8	1032,0	999,1	965,6
	qwr	m³/h	193,00	188,17	182,98	177,51	171,85	166,08
	dpwr	kPa	108,4	103,1	97,4	91,7	86,0	80,3
11°C	Pf	kW	976,7	936,0	890,4	840,3	786,1	728,2
	Pa	kW	178,3	189,8	204,1	221,2	241,2	264,1
	qw	m³/h	167,99	161,00	153,16	144,54	135,21	125,25
	dpw	kPa	82,1	75,4	68,3	60,8	53,2	45,7
	Pr	kW	1155,0	1125,9	1094,6	1061,6	1027,3	992,4
	qwr	m³/h	198,66	193,65	188,27	182,59	176,70	170,68
	dpwr	kPa	114,9	109,2	103,2	97,0	90,9	84,8

Twout = Outlet water temperature (°C);
Twoutr = Heating side heat exchanger leaving water temperature (°C)
Pf = Cooling capacity (kW);
Pr = Recovery mode heating capacity (kW);
Pa = Compressors heating capacity (kW);
qw = Water flow (m³/h);
dpw = Pressure drop (kPa);
qwr = Recovery heat exchanger water flow (m³/h);
dpw = Recovery heat exchanger pressure drop (kPa).

Water flow and pressure drop on heat exchanger calculated with $\Delta T = 5^\circ\text{C}$

(1) Units equipped with the accessory High Performance temperature (HPT), with outlet water temperature up to 65°C.

MULTIPIPE CHILLER RTMA

7. OPERATING RANGE

Version	Operating way	Ta		Tw out	
		Min	Max	Min	Max
Std – SL	Cooling	18	43	-8 ⁽¹⁾	18
Std – SL	Heating	-15	30	25	60/65 ⁽²⁾

(1) Operation with glycol

(2) Units equipped with accessory HPT (High Performance Temperature), with temperatures of producing water of 65 °C.

Ta = Outdoor air temperature (°C)

Tw out = Outlet water temperature (°C)

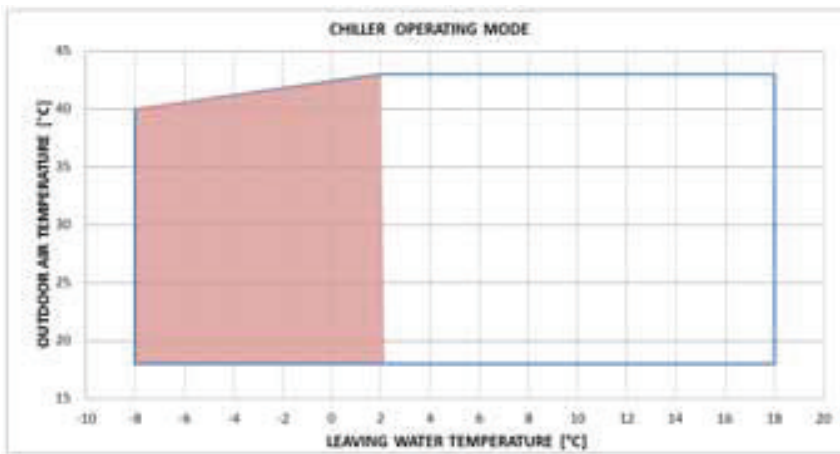

ONLY WITH GLYCOL

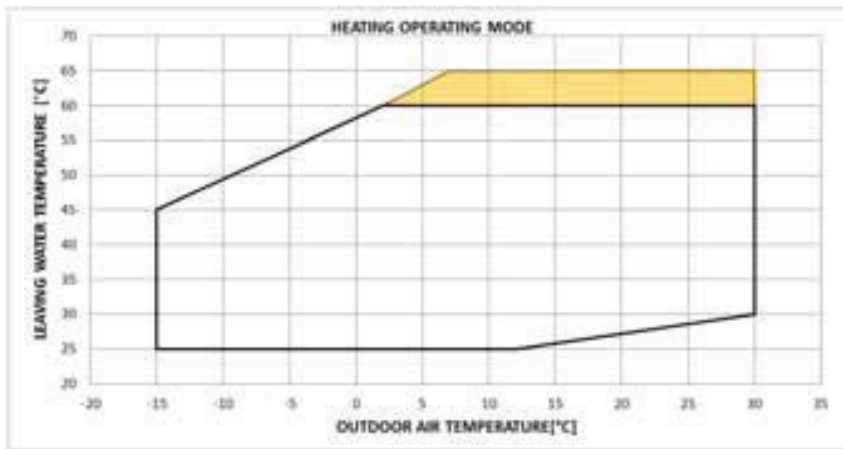

HPT

HPT = Units equipped with the accessory High Performance temperature (HPT), with outlet water temperature up to 65°C.

Beware the air condition is meant as absence of air flow to the unit. Wind condition can let air flow through the condenser coil causing a reduction in the operating limit. In the case of predominant winds, it becomes necessary the use of appropriate wind barriers.

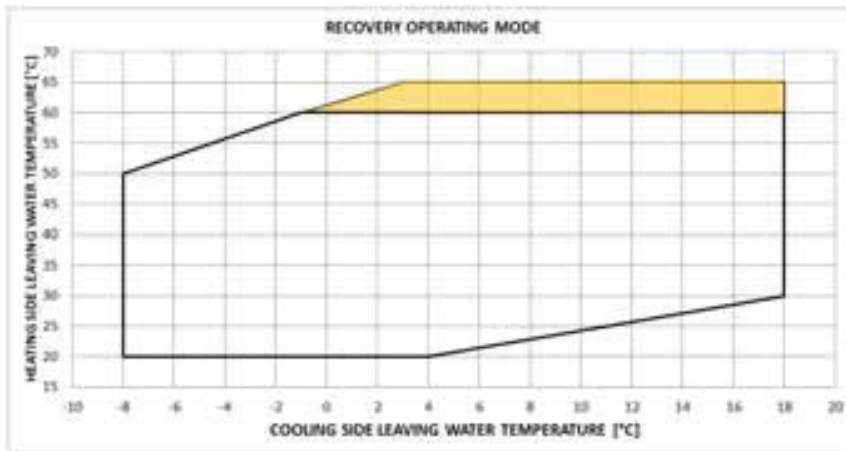

HPT

HPT = Units equipped with the accessory High Performance temperature (HPT), with outlet water temperature up to 65°C.

Beware the air condition is meant as absence of air flow to the unit. Wind condition can let air flow through the condenser coil causing a reduction in the operating limit. In the case of predominant winds, it becomes necessary the use of appropriate wind barriers

8. SCALING CORRECTION SCHEDULES

ETHYLENE GLYCOL CORRECTION SCHEDULE

% Ethilene glicol weight		5%	10%	15%	20%	25%	30%	35%	40%
Freezing temperature	°C	-2	-3,9	-6,5	-8,9	-11,8	-15,6	-19	-23,4
Suggested security limit	°C	3	1	-1	-4	-6	-10	-14	-19
Cooling capacity coefficient	-	0,995	0,99	0,985	0,981	0,977	0,974	0,971	0,968
Power input coefficient	-	0,997	0,993	0,99	0,988	0,986	0,984	0,982	0,981
Flow rate coefficient	-	1,003	1,01	1,02	1,033	1,05	1,072	1,095	1,124
Pressur dropo coefficient	-	1,029	1,06	1,09	1,118	1,149	1,182	1,211	1,243

In order to calculate performance with glycolated solutions multiply main sizes by respective coefficients.

GLICOLE PERCENTAGE DEPENDING ON FREEZING TEMPERATURE

% glycol according to the freezing temperature							
Freezing temperature	0°C	-5°C	-10°C	-15°C	-20°C	-25°C	
% Ethilene glycol	5%	12%	20%	28%	35%	40%	
Flow rate coefficient	1,02	1,033	1,05	1,072	1,095	1,124	

In order to calculate performance with glycolated solutions multiply main sizes by respective coefficients.

FOULING FACTOR CORRECTION TABLE

Fouling Factor	Plant side cold heat exchanger			Plant side hot heat exchanger		
	A1	B1	Tmin	A2	B2	Tmax
F.F. [m ² °C*W]						
0	1,00	1,00	0,00	1,00	1,00	0,00
1,80E-05	1,00	1,00	0,00	1,00	1,00	0,00
4,40E-05	1,00	1,00	0,00	0,99	1,03	1,00
8,80E-05	0,96	0,99	0,70	0,98	1,04	1,50
1,32E-04	0,94	0,99	1,00	0,96	1,05	2,30
1,72E-04	0,93	0,98	1,50	0,95	1,06	3,00

A factor

B factor

Tmin

T max

Capacity correction factor

Compressor power input correction factor

Minimum evaporator outlet water temperature increase

Maximum condenser outlet water temperature decrease

9. HYDRAULIC DATA

9.1 WATER FLOW AND PRESSURE DROP

RTMA	plant side cold heat exchanger				plant side hot heat exchanger			
	V [m ³]	K	Q min [m ³ /h]	Q max [m ³ /h]	V [m ³]	K	Q min [m ³ /h]	Q max [m ³ /h]
105	3,8	17,1	39,6	105,7	11,9	17,1	44,3	118,0
115	4,2	10,1	43,8	116,9	13,4	10,1	49,9	133,0
120	4,4	9,6	45,8	122,1	13,9	9,6	52,0	138,8
130	4,7	9,0	49,8	132,9	15,2	9,0	56,7	151,2
150	5,4	8,2	56,9	151,7	17,1	8,2	63,9	170,3
170	6,1	7,8	63,9	170,3	19,4	7,8	72,6	193,7
180	6,4	7,6	67,3	179,5	20,1	7,6	75,2	200,5
190	6,8	3,0	71,6	191,0	20,6	3,0	77,2	205,9
210	7,5	2,9	78,8	210,1	23,3	2,9	87,3	232,7
105 LN	3,8	17,1	38,2	102,0	11,9	17,1	38,2	119,4
115 LN	4,2	10,1	42,5	113,3	13,4	10,1	42,5	134,5
120 LN	4,4	9,6	44,4	118,5	13,9	9,6	44,4	140,4
130 LN	4,7	9,0	48,3	128,9	15,2	9,0	48,3	152,8
150 LN	5,4	8,2	55,5	147,9	17,1	8,2	55,5	172,0
170 LN	6,1	7,8	62,3	166,1	19,4	7,8	62,3	195,6
180 LN	6,4	7,6	65,6	174,8	20,1	7,6	65,6	202,5
190 LN	6,8	3,0	69,9	186,3	20,6	3,0	69,9	207,9
210 LN	7,5	2,9	76,8	204,9	23,3	2,9	76,8	235,1
105 SL	3,8	17,1	39,2	104,7	11,9	17,1	39,2	120,3
115 SL	4,2	10,1	43,5	115,9	13,4	10,1	43,5	135,6
120 SL	4,4	9,6	45,4	121,1	13,9	9,6	45,4	141,4
130 SL	4,7	9,0	49,4	131,8	15,2	9,0	49,4	153,9
150 SL	5,4	8,2	56,5	150,7	17,1	8,2	56,5	173,1
170 SL	6,1	7,8	63,4	169,2	19,4	7,8	63,4	196,9
180 SL	6,4	7,6	66,8	178,2	20,1	7,6	66,8	203,8
190 SL	6,8	3,0	71,1	189,7	20,6	3,0	71,1	209,3
210 SL	7,5	2,9	78,3	208,7	23,3	2,9	78,3	236,6

V: recommended water content of the plant (cold side and hot side) with ΔT 5 ° C on the heat exchanger

Q min: minimum water flow to the heat exchanger

Q max: maximum water flow to the heat exchanger

$$dpw = K \cdot Q^2 / 1000$$

$$Q = 0,86 \sqrt{P / \Delta t}$$

P: Heating/cooling capacity [kW]

Δt : ΔT at the heat exchanger (min = 3, max = 8) [°C]

dpw: Pressure drop [kPa]

10.2 HYDRONIC GROUP

The units of the **RTMA** family are also available in multiple hydraulic versions, characterized by complete kits of all major hydraulic components for an easier installation, with reduced time, cost and space. The wide range of hydraulic versions available make the unit suitable for any type of installation.

HYDRAULIC VERSIONS

- pumps low head pressure 150kPa
- 2 pumps medium head pressure 250kPa
- 2 pumps high head pressure 450kPa

HYDRONIC KIT

Centrifugal pumps with 2 or 4 poles, axial suction bowls and radial delivery, available in low, medium or high head pressure.

Pumps with cast iron body and impeller entirely welded using laser technology. Mechanical seal with ceramic components, coal and EPDM elastomers. Three phase electric motor with IP55 protection and insulation class F, suitable for continuous service.

Series motors with higher efficiency IE2 technology.

- Differential pressure switch on exchanger
- Discharge taps
- Taps on pumps suction / delivery which allow the replacement of a damaged pump eliminating the plant shutdown differently from other types of common use.
- Check valve
- Relief valve
- Discharge valve
- Minimum pressure switch for automatic changeover of the pumps.

The stand by pump accessory is also available , including 2 additional pumps(one for the cold circuit and the other for the hot circuit) in stand-by mode to the first, equipped with the automatic changeover including also the pressure switch for the intervention of the second pump.The pumps operate with the balance of the related working hours. In case of failure of one pump the controller in automatic switches on the additional pump. The control panel is equipped with fuses and contactor with thermal protection.

HYDRONIC ACCESORIES ON REQUEST

- "Y" water strainer (sold separately), consists of body and stainless steel mesh, with replaceable filter through the inspection cap.
- Automatic water filling (sold separately).
- Stand by pump for air conditionin circuit + stand by pump for heating circuit ,150 kPa
- Stand by pump for air conditionin circuit + stand by pump for heating circuit ,250 kPa
- Stand by pump for air conditionin circuit + stand by pump for heating circuit ,450 kPa

LOW HEAD PRESSURE PUMP (150kPa)

COOLING MODE

RTMA 105 - 210

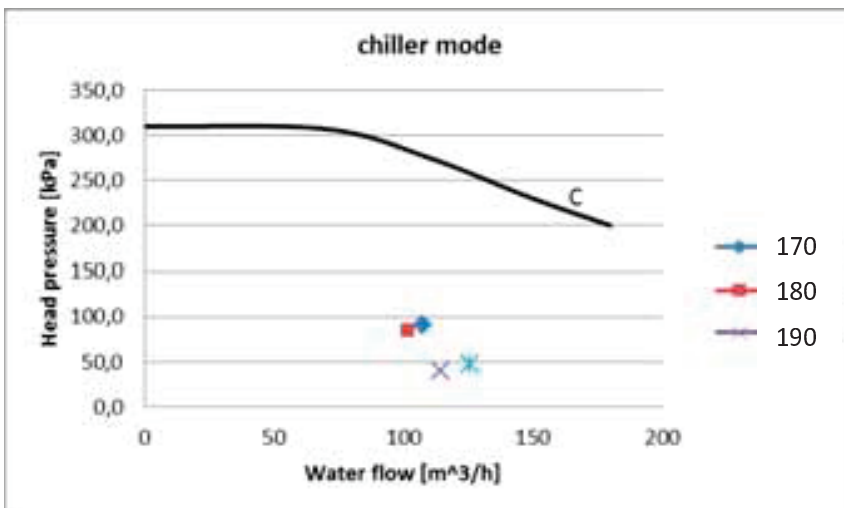
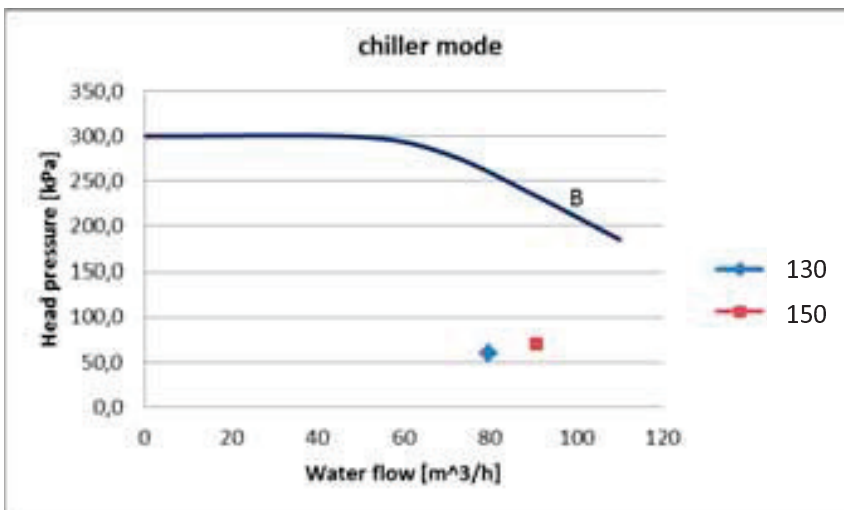
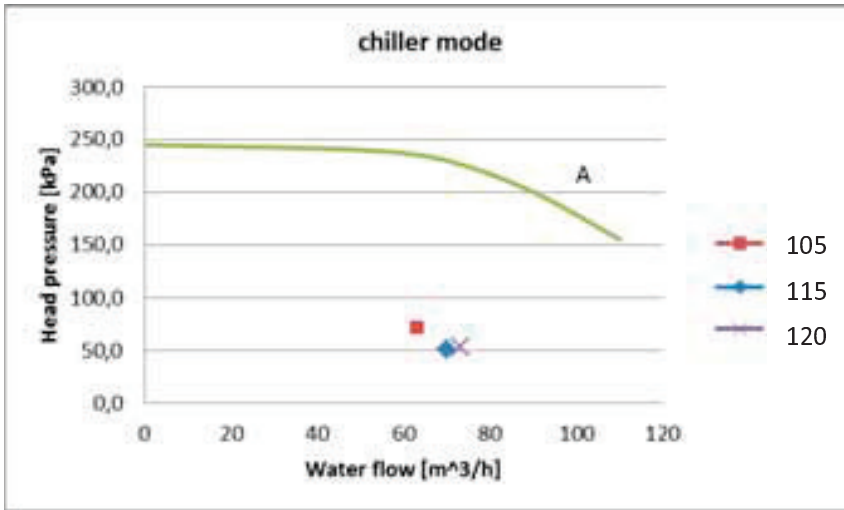

MULTIPIPE CHILLER RTMA

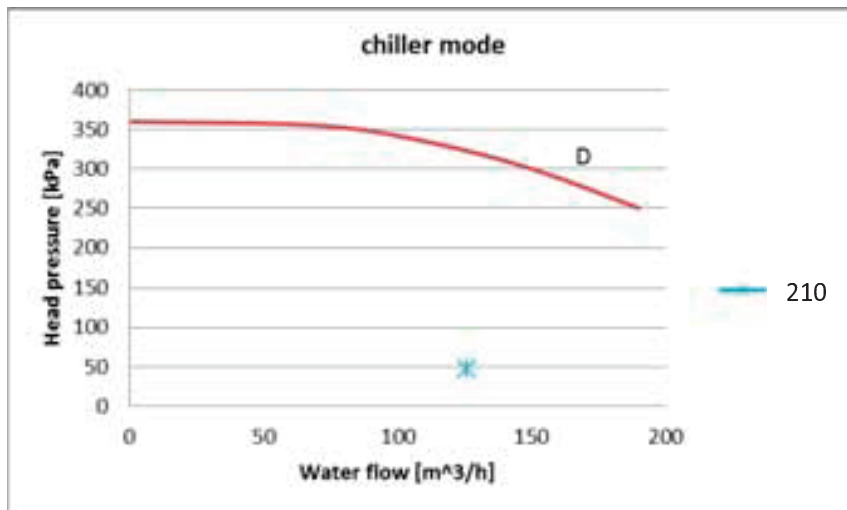

Mod.	Pf	qw	dpw	Ref. curve	Expansion vessel	F.L.I.	F.L.A.	Hp	Hu
	kW	m3/h	kPa		[l]	kW	A	kPa	kPa
105	368,70	63,3	72	A	2x24	7,5	14,2	237,2	165,2
115	407,70	70,0	51	A	2x24	7,5	14,2	232,8	181,4
120	426,00	73,1	53	A	2x24	7,5	14,2	230,3	176,9
130	463,50	79,5	59	B	2x24	9	16,5	259,9	200,6
150	529,20	90,8	70	B	2x24	9	16,5	236,0	165,6
170	594,20	102,0	84	C	2x24	15	25,8	282,9	198,7
180	626,20	107,4	91	C	2x24	15	25,8	278,6	187,8
190	666,30	114,3	40	C	2x24	15	25,8	272,9	232,7
210	733,00	125,8	48	D	2x24	18,5	32,9	262,4	214,6

Pf Cooling capacity (kW)

qw Water flow (m3/h)

dpw Pressure drop (kPa)

F.L.I. Full load electrical power input

F.L.A. Full load operating current

Hp Pump Head pressure

Hu Available head pressure

HEATING MODE

RTMA 105- 210

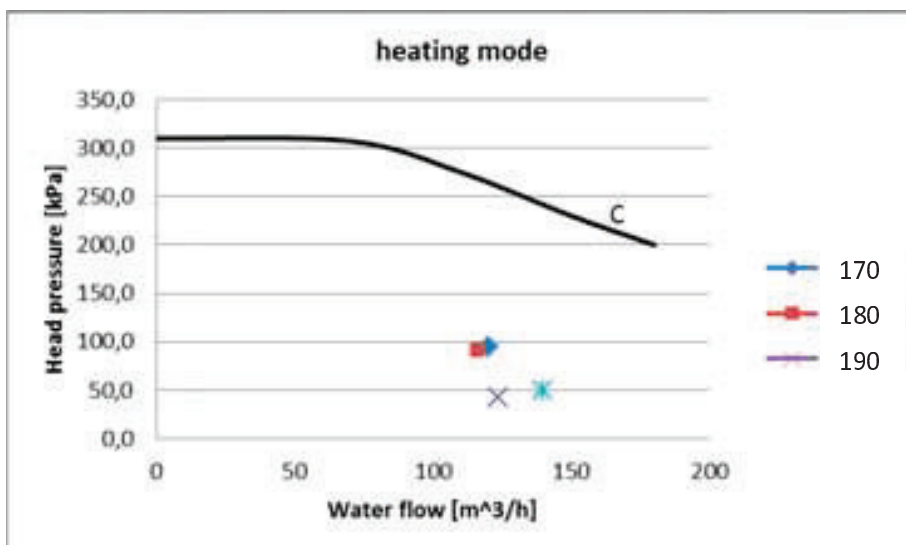
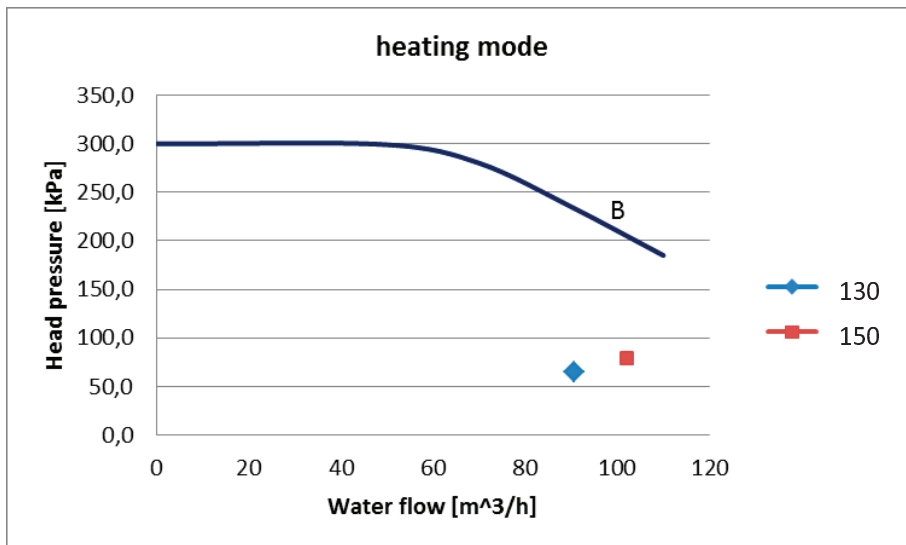
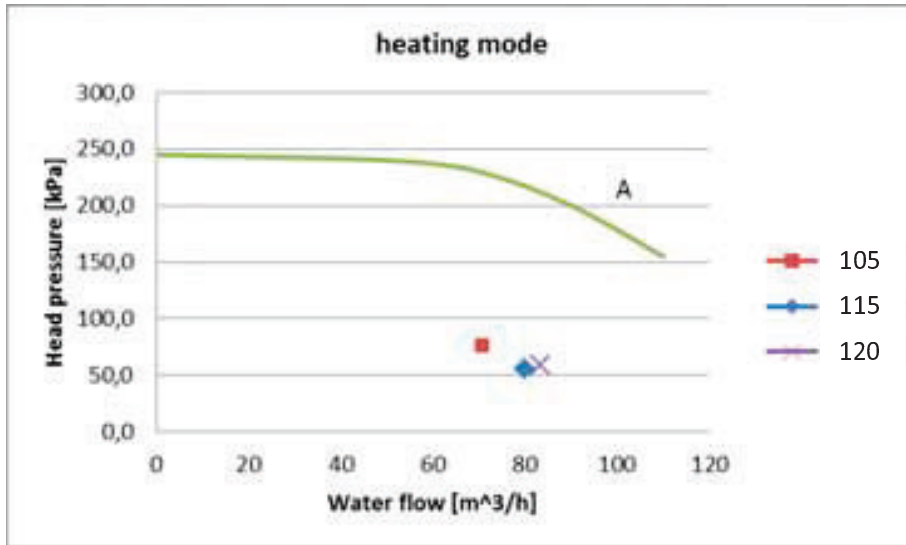

MULTIPIPE CHILLER RTMA

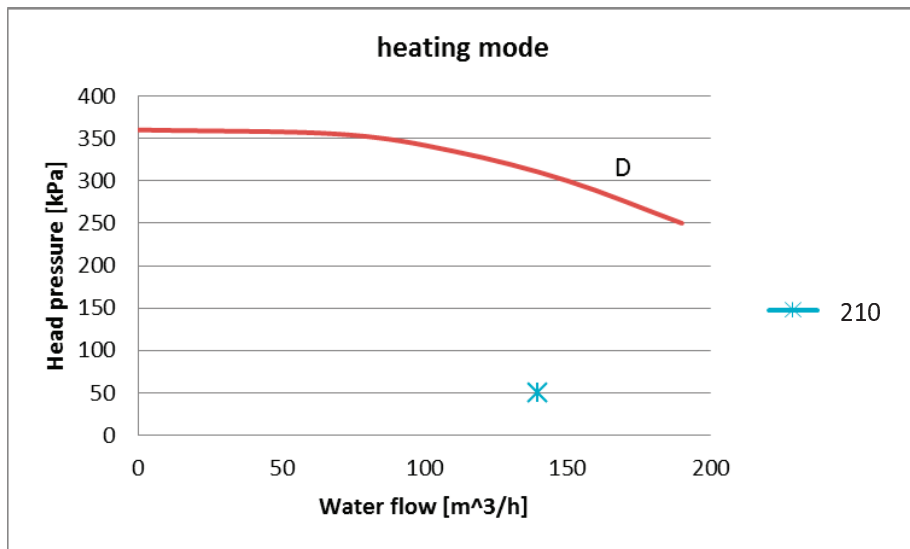

Mod.	Pt	qw	dpw	Ref. curve	Expansion vessel [l]	F.L.I.	F.L.A.	Hp	Hu
	kW	m ³ /h	kPa			kW	A		
105	411,80	70,8	76	A	2x24	7,5	14,2	237,2	165,2
115	464,10	79,8	56	A	2x24	7,5	14,2	232,8	181,4
120	484,10	83,3	59	A	2x24	7,5	14,2	230,3	176,9
130	527,50	90,7	65	B	2x24	9	16,5	259,9	200,6
150	594,10	102,2	78	B	2x24	9	16,5	236,0	165,6
170	675,70	116,2	91	C	2x24	15	25,8	282,9	198,7
180	699,40	120,3	95	C	2x24	15	25,8	278,6	187,8
190	718,10	123,5	43	C	2x24	15	25,8	272,9	232,7
210	811,90	139,6	50	D	2x24	18,5	32,9	262,4	214,6

Pt Heating capacity (kW)

qw Water flow (m³/h)

dpw Pressure drop (kPa)

F.L.I. Full load electrical power input

F.L.A. Full load operating current

Hp Pump Head pressure

Hu Available head pressure

MEDIUM HEAD PRESSURE PUMP (250kPa)

COOLING MODE

RTMA 105 - 150

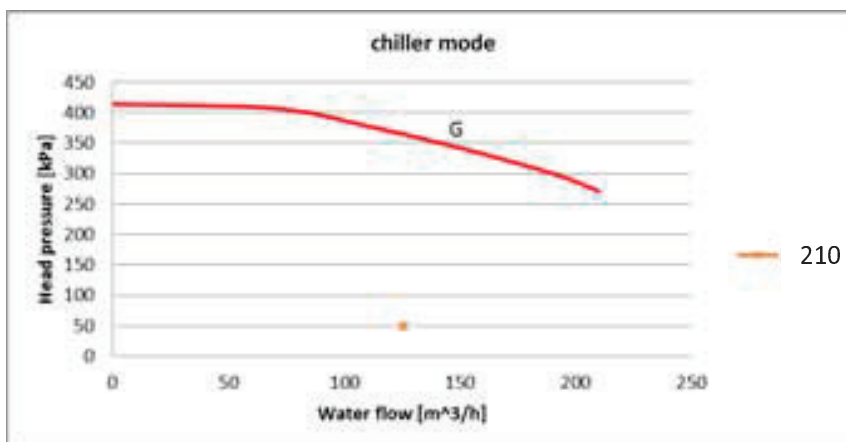
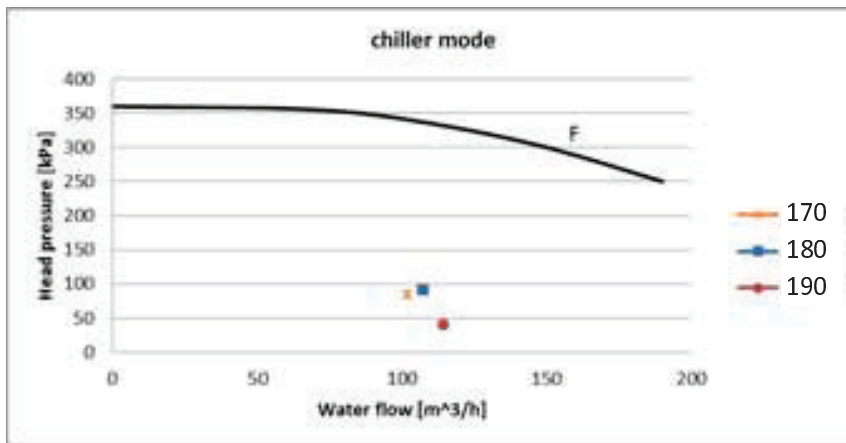
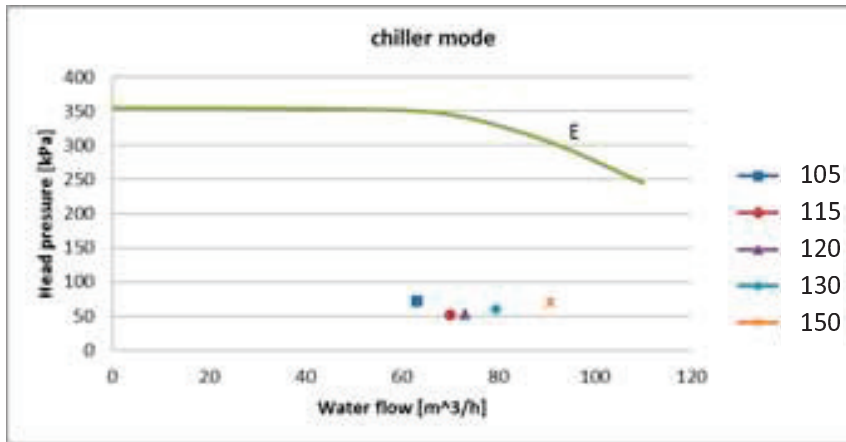

MULTIPIPE CHILLER RTMA

Mod.	Pf	qw	dpw	Ref. curve	Expansion vessel	F.L.I.	F.L.A.	Hp	Hu
	kW	m3/h	kPa			[l]	kW	A	kPa
105	368,70	63,3	72	E	2x24	11	19,3	348,2	276,2
115	407,70	70,0	51	E	2x24	11	19,3	342,2	290,8
120	426,00	73,1	53	E	2x24	11	19,3	338,7	285,3
130	463,50	79,5	59	E	2x24	11	19,3	329,6	270,3
150	529,20	90,8	70	E	2x24	11	19,3	307,0	236,5
170	594,20	102,0	84	F	2x24	18,5	32,9	340,3	256,1
180	626,20	107,4	91	F	2x24	18,5	32,9	336,8	246,0
190	666,30	114,3	40	F	2x24	18,5	32,9	332,1	291,9
210	733,00	125,8	48	G	2x24	22	39	366,8	319,1

Pf Cooling capacity (kW)

qw Water flow (m3/h)

dpw Pressure drop (kPa)

F.L.I. Full load electrical power input

F.L.A. Full load operating current

Hp Pump Head pressure

Hu Available head pressure

HEATING MODE

RTMA 105 -210

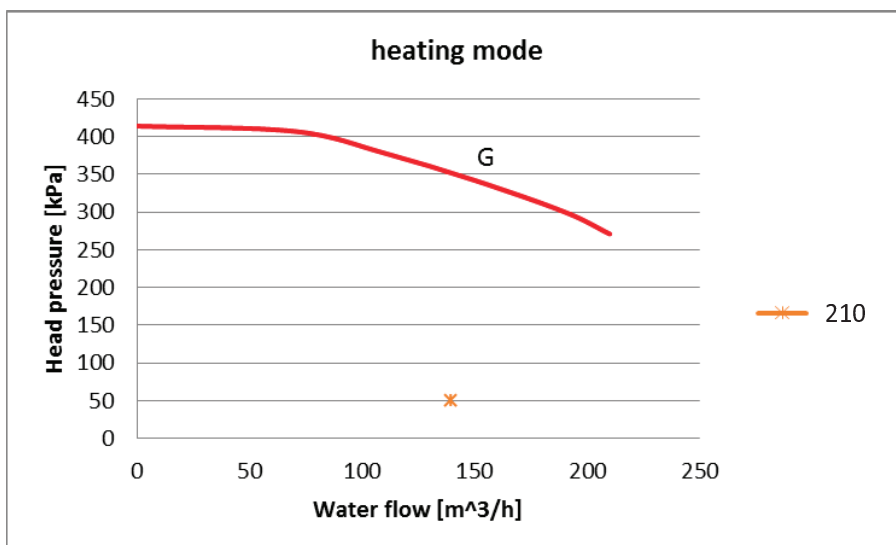
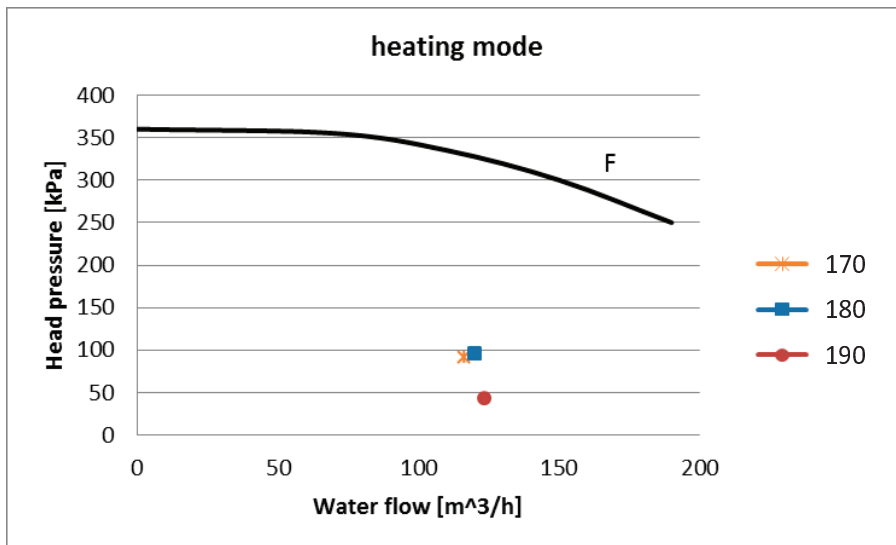
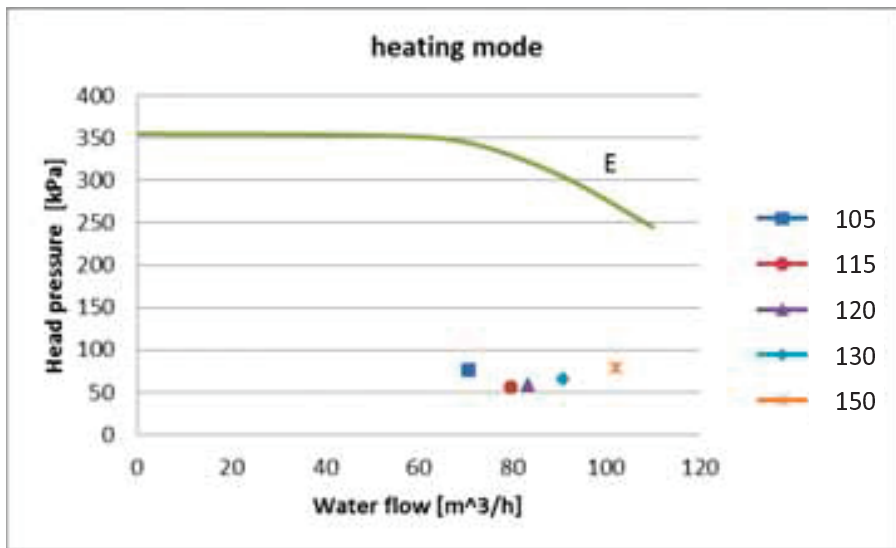

MULTIPIPE CHILLER RTMA

Mod.	Pf	qw	dpw	Ref. curve	Expansion vessel [l]	F.L.I.	F.L.A.	Hp	Hu
	kW	m ³ /h	kPa			kW	A	kPa	kPa
105	411,80	70,8	76	E	2x24	7,5	14,2	341,3	265,3
115	464,10	79,8	56	E	2x24	7,5	14,2	329,1	273,0
120	484,10	83,3	59	E	2x24	7,5	14,2	323,1	264,1
130	527,50	90,7	65	E	2x24	9	16,5	307,1	241,7
150	594,10	102,2	78	E	2x24	9	16,5	274,1	196,0
170	675,70	116,2	91	F	2x24	15	25,8	330,8	239,6
180	699,40	120,3	95	F	2x24	15	25,8	327,7	232,7
190	718,10	123,5	43	F	2x24	15	25,8	325,2	282,4
210	811,90	139,6	50	G	2x24	18,5	32,9	354,3	304,6

Pt Heating capacity (kW)

qw Water flow (m³/h)

dpw Pressure drop (kPa)

F.L.I. Full load electrical power input

F.L.A. Full load operating current

Hp Pump Head pressure

Hu Available head pressure

HIGH HEAD PRESSURE PUMP (450kPa)

COOLING MODE

RTMA 150 - 210

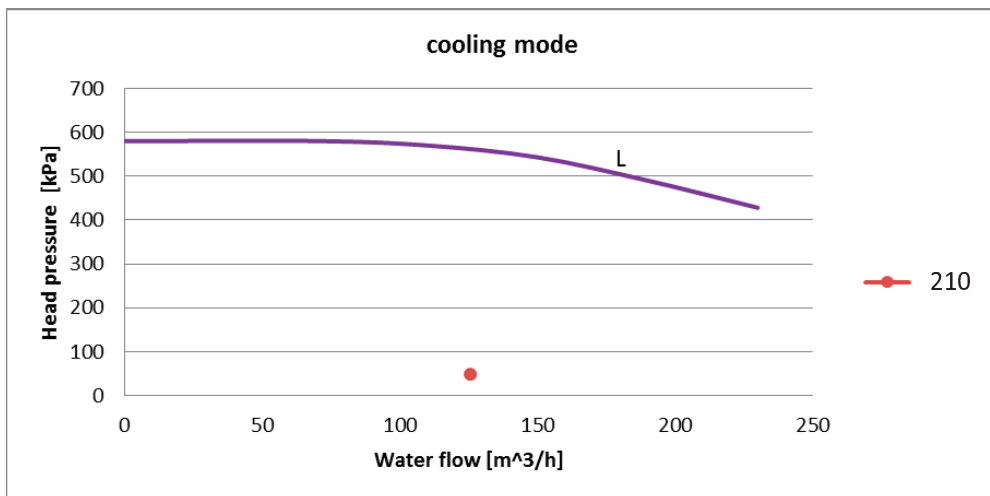
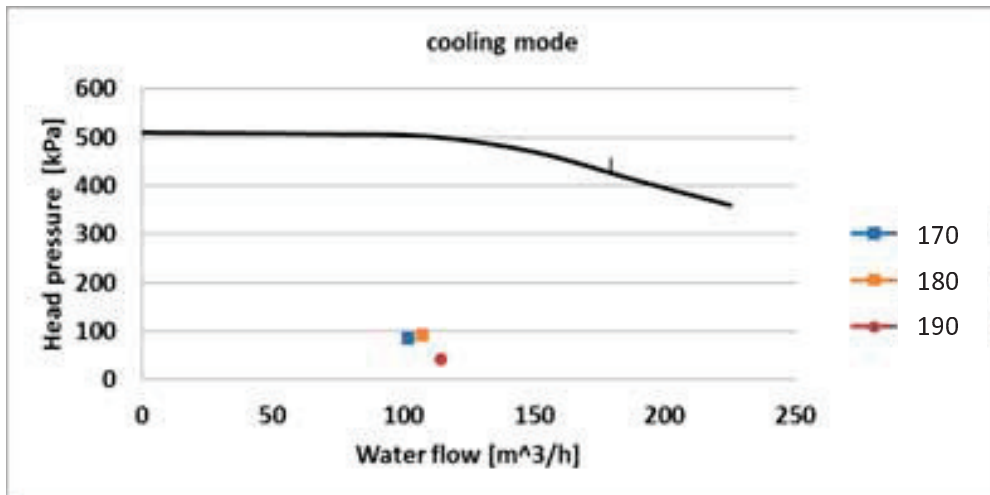
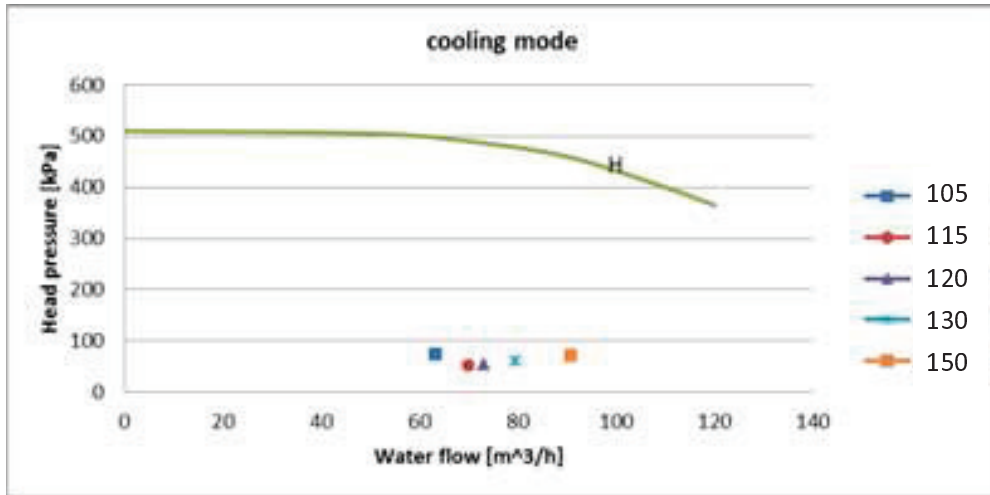

MULTIPIPE CHILLER RTMA

Mod.	Pf	qw	dpw	Ref. curve	Expansion vessel	F.L.I.	F.L.A.	Hp	Hu
	kW	m3/h	kPa		[l]	kW	A	kPa	kPa
105	368,70	63,3	72	H	2x24	11	18,5	32,9	433,8
115	407,70	70,0	51	H	2x24	11	18,5	32,9	450,8
120	426,00	73,1	53	H	2x24	11	18,5	32,9	446,8
130	463,50	79,5	59	H	2x24	11	18,5	32,9	435,8
150	529,20	90,8	70	H	2x24	11	18,5	32,9	412,2
170	594,20	102,0	84	I	2x24	18,5	30	54,0	417,6
180	626,20	107,4	91	I	2x24	18,5	30	54,0	408,2
190	666,30	114,3	40	I	2x24	18,5	30	54,0	455,0
210	733,00	125,8	48	L	2x24	22	37	63,0	511,5

Pf Cooling capacity (kW)

Pt Heating capacity (kW)

qw Water flow (m3/h)

dpw Pressure drop (kPa)

F.L.I. Full load electrical power input

F.L.A. Full load operating current

Hp Pump Head pressure

Hu Available head pressure

HEATING MODE

RTMA 105 – 210

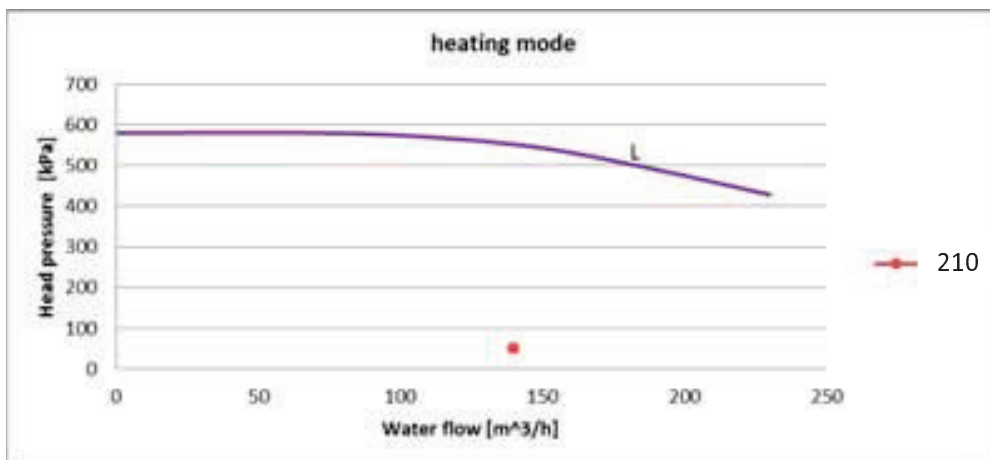
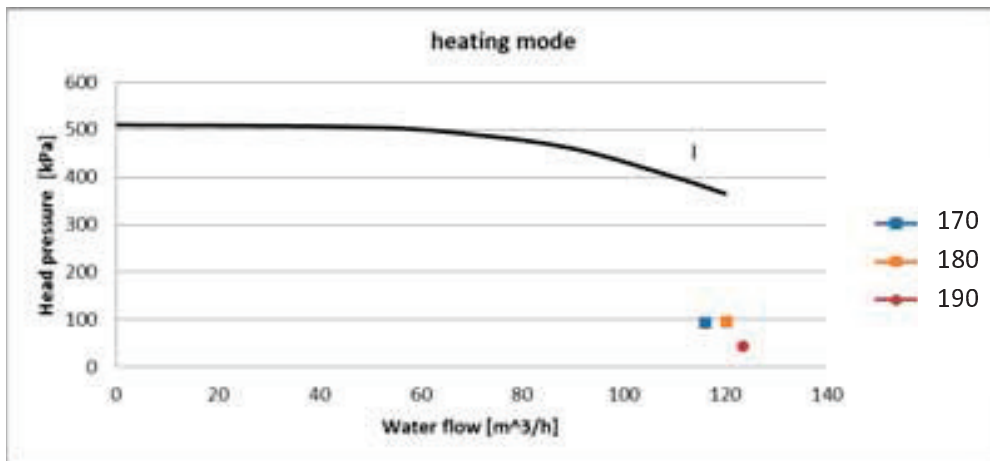
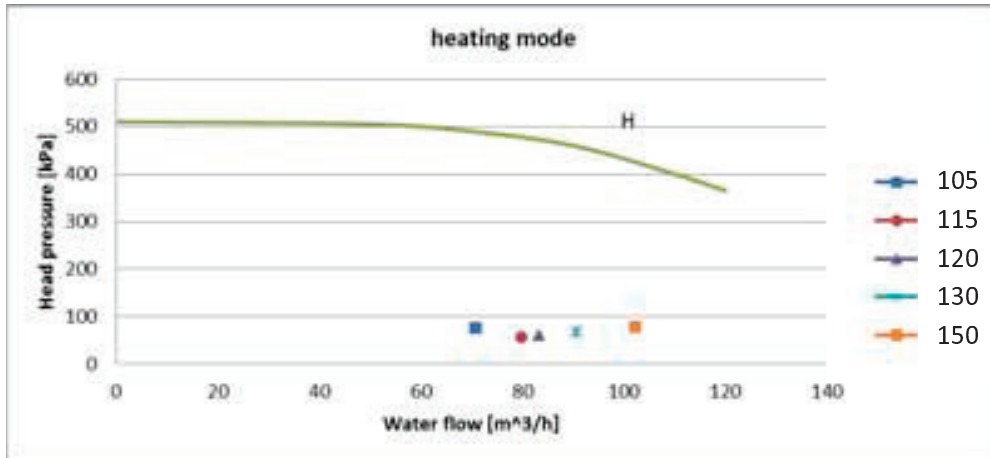

MULTIPIPE CHILLER RTMA

Mod.	Pt	qw	dpw	Ref. curve	Expansion vessel [l]	F.L.I.	F.L.A.	Hp	Hu
	kW	m3/h	kPa			kW	A	kPa	kPa
105	411,80	70,8	76	H	2x24	18,5	32,9	501,7	425,7
115	464,10	79,8	56	H	2x24	18,5	32,9	494,8	438,7
120	484,10	83,3	59	H	2x24	18,5	32,9	491,4	432,5
130	527,50	90,7	65	H	2x24	18,5	32,9	482,7	417,3
150	594,10	102,2	78	H	2x24	18,5	32,9	464,7	386,6
170	675,70	116,2	91	I	2x24	30	54	494,1	402,9
180	699,40	120,3	95	I	2x24	30	54	491,5	396,5
190	718,10	123,5	43	I	2x24	30	54	489,4	446,5
210	811,90	139,6	50	L	2x24	37	63	548,0	498,4

Pt Heating capacity (kW)

qw Water flow (m3/h)

dpw Pressure drop (kPa)

F.L.I. Full load electrical power input

F.L.A. Full load operating current

Hp Pump Head pressure

Hu Available head pressur

CONNECTION SCHEME - STANDARD VERSION

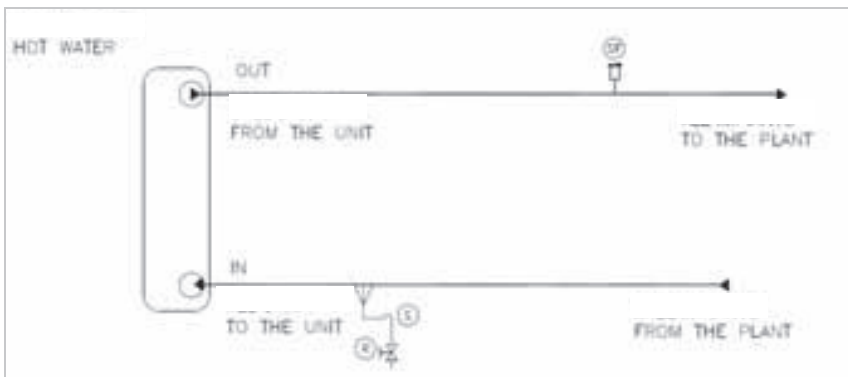
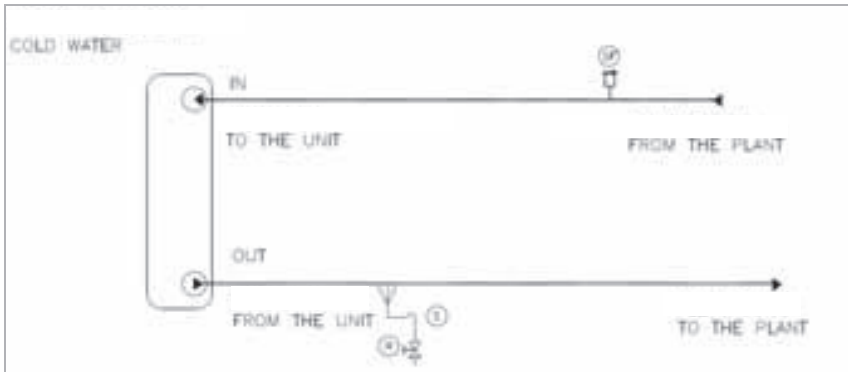

- S Water discharge
- SF Relief valve
- R Shut off valve

MULTIPIPE CHILLER RTMA

HYDRONIC KIT WITH 1 PUMP HOT SIDE + 1 PUMP COLD SIDE

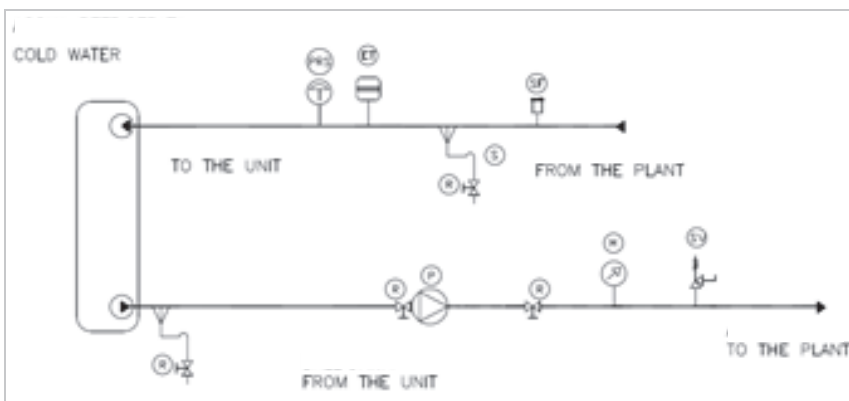
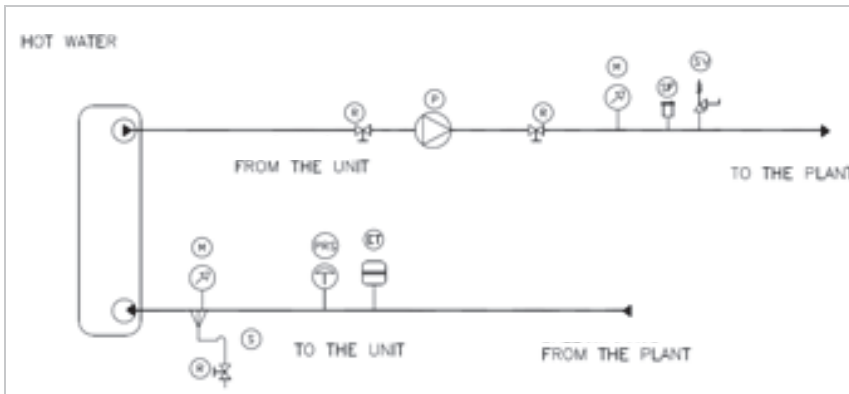

- M Gauges
- S Water discharge
- P Pump
- SV Safety valve
- SF Relief valve
- ET Expansion vessel
- PRS Empty plant security pressure switch
- R Shut off valve

HYDRONIC KIT WITH 2 HOT SIDE PUMPS + 2 COLD SIDE PUMPS

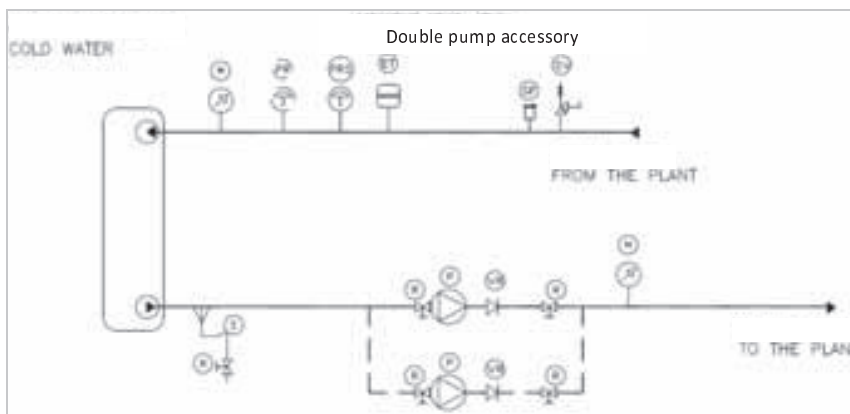
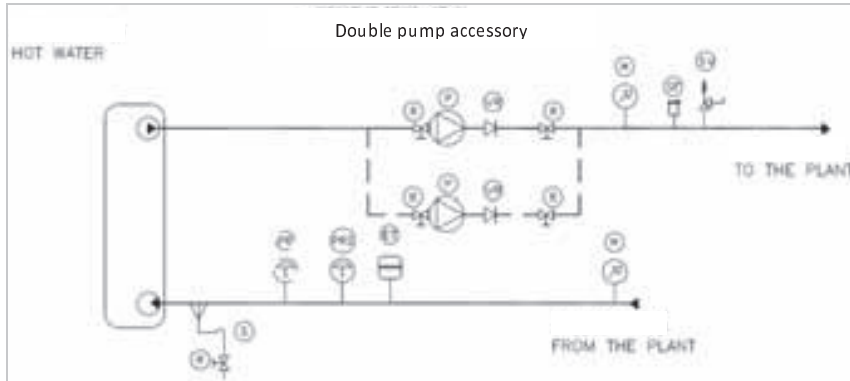

- M Gauges
- S Water discharge
- P Pump
- SV Safety valve
- SF Relief valve
- ET Expansion vessel
- PD Water differential pressure switch
- PRS Empty plant security pressure switch
- R Shut off valve
- PR Additional pump water pressure switch
- VR Check valve

MULTIPIPE CHILLER RTMA

10. ELECTRICAL DATA

RTMA

NOMINAL VALUES									MAX VALUES (1)		
Outdoor air temperature 35 ° C, evaporator water temperature in / out 12/7 ° C											
Mod.	Compressors (2)		Fans			TOTAL			TOTAL		
	F.L.I.	F.L.A.	L.R.A	E.P.	O.C.	F.L.I.	F.L.A.	S.A.	F.L.I.	F.L.A.	S.A.
	kW	A	A	kW	A	kW	A	A	kW	A	A
105	113,5	192,9	405	12,0	24,0	125,5	216,9	485,7	202,4	344	589
115	127,2	216,2	434	12,0	24,0	139,2	240,2	521,6	214,1	364	618
120	131,0	225,9	434	15,0	30,0	147,9	255,9	529,5	217,6	370	624
130	137,1	233,1	434	15,0	30,0	152,1	263,1	532,6	229,4	390	644
150	156,1	265,4	530	18,0	36,0	174,1	301,4	644,1	254,1	432	764
170	168,8	287,0	587	18,0	36,0	186,8	323,0	707,4	281,2	478	844
180	182,4	310,1	587	18,0	36,0	200,4	346,1	714,2	317,6	540	906
190	193,4	328,8	587	21,0	42,0	214,4	370,8	725,7	321,2	546	912
210	214,0	363,8	436	21,0	42,0	235,0	405,8	585	357,6	608	761

RTMA LN

NOMINAL VALUES									MAX VALUES (1)		
Outdoor air temperature 35 ° C, evaporator water temperature in / out 12/7 ° C											
Mod.	Compressors (2)		Fans			TOTAL			TOTAL		
	F.L.I.	F.L.A.	L.R.A	E.P.	O.C.	F.L.I.	F.L.A.	S.A.	F.L.I.	F.L.A.	S.A.
	kW	A	A	kW	A	kW	A	A	kW	A	A
105	113,5	192,9	405,0	12,0	24,0	125,5	216,9	525,5	202,4	344,0	589,0
115	127,2	216,2	434,0	12,0	24,0	139,2	240,2	566,1	214,1	364,0	618,0
120	132,9	225,9	434,0	15,0	30,0	147,9	255,9	577,0	217,6	370,0	624,0
130	137,1	233,1	434,0	15,0	30,0	152,1	263,1	580,5	229,4	390,0	644,0
150	156,1	265,4	530,0	18,0	36,0	174,1	301,4	698,7	254,1	432,0	764,0
170	168,8	287,0	587,0	18,0	36,0	186,8	323,0	766,5	281,2	478,0	844,0
180	182,4	310,1	587,0	18,0	36,0	200,4	346,1	778,0	317,6	540,0	906,0
190	193,4	328,8	587,0	21,0	42,0	214,4	370,8	793,4	321,2	546,0	912,0
210	214,0	363,8	436,0	21,0	42,0	235,0	405,8	659,9	357,6	608,0	761,0

RTMA SL

NOMINAL VALUES									MAX VALUES (1)		
Outdoor air temperature 35 ° C, evaporator water temperature in / out 12/7°C											
Mod.	Compressors (2)		Fans			TOTAL			TOTAL		
	F.L.I.	F.L.A.	L.R.A	E.P.	O.C.	F.L.I.	F.L.A.	S.A.	F.L.I.	F.L.A.	S.A.
	kW	A	A	kW	A	kW	A	A	kW	A	A
105	114,4	194,6	405	8,4	16,8	125,5	216,9	525,5	198,1	336,8	581,8
115	128,2	217,9	434	8,4	16,8	139,2	240,2	566,1	209,9	356,8	610,8
120	124,8	212,1	434	10,5	21,0	147,9	255,9	577	212,4	361	615
130	138,3	235,1	434	10,5	21,0	152,1	263,1	580,5	224,1	381	635
150	157,5	267,7	530	12,6	25,2	174,1	301,4	698,7	247,8	421,2	753,2
170	170,3	289,5	587	12,6	25,2	186,8	323,0	766,5	274,8	467,2	833,2
180	184,0	312,8	587	12,6	25,2	200,4	346,1	778	311,3	529,2	895,2
190	195,1	331,6	587	14,7	29,4	214,4	370,8	793,4	313,8	533,4	899,4
210	215,9	367,0	436	14,7	29,4	235,0	405,8	659,9	350,2	595,4	748,4

Electrical data referred to 400V - 3PH+N-50Hz

Maximum operating admitted conditions: 10%

Maximum phase unbalance: 3%

F.L.I. full load electrical power

F.L.A. full load operating current

L.R.A. compressor motor locked rotor current (direct starting)

S.A. sum of LRA of the most powerful compressor, FLA of other compressor and fans current

E.P. electrical power

O.C. operating current

(1) maximum operating admitted conditions by the compressors manufacturer

(2) data referred to the biggest compressor for units with different compressors

MULTIPIPE CHILLER RTMA

11. ACOUSTIC DATA

RTMA

Model	Octave Band (Hz)								Lw eq dB(A)
	63	125	250	500	1000	2000	4000	8000	
	Lw dB(A)								
105	68,9	64,9	60,3	56,1	53,7	68,9	51,4	40,4	92
115	68,9	64,9	60,3	56,1	53,7	68,9	51,4	40,4	92
120	69,8	65,8	61,2	57,0	54,6	69,8	52,3	41,3	93
130	69,8	65,8	61,2	57,0	54,6	69,8	52,3	41,3	93
150	71,7	67,7	63,1	58,9	56,5	71,7	54,2	43,2	95
170	71,7	67,7	63,1	58,9	56,5	71,7	54,2	43,2	95
180	71,7	67,7	63,1	58,9	56,5	71,7	54,2	43,2	95
190	72,5	68,5	63,9	59,7	57,3	72,5	55,0	44,0	96
210	72,5	68,5	63,9	59,7	57,3	72,5	55,0	44,0	96

RTMA LN

Model	Octave Band (Hz)								Lw eq dB(A)
	63	125	250	500	1000	2000	4000	8000	
	Lw dB(A)								
105	66,9	62,9	58,3	54,1	51,7	66,9	49,4	38,4	90
115	66,9	62,9	58,3	54,1	51,7	66,9	49,4	38,4	90
120	67,8	63,8	59,2	55,0	52,6	67,8	50,3	39,3	91
130	67,8	63,8	59,2	55,0	52,6	67,8	50,3	39,3	91
150	69,7	65,7	61,1	56,9	54,5	69,7	52,2	41,2	93
170	69,7	65,7	61,1	56,9	54,5	69,7	52,2	41,2	93
180	69,7	65,7	61,1	56,9	54,5	69,7	52,2	41,2	93
190	70,5	66,5	61,9	57,7	55,3	70,5	53,0	42,0	94
210	70,5	66,5	61,9	57,7	55,3	70,5	53,0	42,0	94

RTMA SL

Model	Octave Band (Hz)								Lw eq dB(A)
	63	125	250	500	1000	2000	4000	8000	
	Lw dB(A)								
105	63,9	59,9	55,3	51,1	48,7	63,9	46,4	35,4	87
115	63,9	59,9	55,3	51,1	48,7	63,9	46,4	35,4	87
120	64,8	60,8	56,2	52,0	49,6	64,8	47,3	36,3	88
130	64,8	60,8	56,2	52,0	49,6	64,8	47,3	36,3	88
150	66,7	62,7	58,1	53,9	51,5	66,7	49,2	38,2	90
170	66,7	62,7	58,1	53,9	51,5	66,7	49,2	38,2	90
180	66,7	62,7	58,1	53,9	51,5	66,7	49,2	38,2	90
190	67,6	63,6	59,0	54,8	52,4	67,6	50,1	39,1	91
210	67,6	63,6	59,0	54,8	52,4	67,6	50,1	39,1	91

CONVERSION FROM SOUND POWER LEVEL TO SOUND PRESSURE LEVEL

$$L_p = L_w + CF$$

L_p = Sound pressure level [dB(A)]

L_w = Sound power level [dB(A)]

CF = Correction factor [dB(A)]

Example:

L_w = 89 dB(A)

L_p (1 m) = 89 dB(A) – 11 dB(A) = 78 dB(A)

Correction factor for Sound Pressure Level at 1, 5, 10, 30 mt distance	
Distance	Correction factor
[m]	[dB (A)]
1	-11,0
5	-25,0
10	-31,0
20	-37,0
30	-40,5

NOISE CORRECTION FACTORS FOR HYDRAULIC VERSION

For the Hydraulic version please consider the noise output increase due to the addition of the hydraulic group.

RTMA

Model	Low head pressure		Medium head pressure		High head pressure	
	1 pump	2 pump	1 pump	2 pump	1 pump	2 pump
	[dB(A)]	[dB(A)]	[dB(A)]	[dB(A)]	[dB(A)]	[dB(A)]
105	-	1	-	1	-	1
115	-	1	-	1	-	1
120	-	1	-	1	-	1
130	-	1	-	1	-	1
150	-	1	-	1	-	1
170	-	1	-	1	1	1
180	-	1	-	1	1	1
190	-	1	-	1	-	1
210	-	1	-	1	1	1

MULTIPIPE CHILLER RTMA

RTMA LN

Model	Low head pressure		Medium head pressure		High head pressure	
	1 pump	2 pump	1 pump	2 pump	1 pump	2 pump
	[dB(A)]	[dB(A)]	[dB(A)]	[dB(A)]	[dB(A)]	[dB(A)]
105	-	1	-	1	-	1
115	-	1	-	1	-	1
120	-	1	-	1	-	1
130	-	1	-	1	-	1
150	-	1	-	1	-	1
170	-	1	-	1	1	1
180	-	1	-	1	1	1
190	-	1	-	1	1	1
210	-	1	-	1	1	1

RTMA SL

Model	Low head pressure		Medium head pressure		High head pressure	
	1 pump	2 pump	1 pump	2 pump	1 pump	2 pump
	[dB(A)]	[dB(A)]	[dB(A)]	[dB(A)]	[dB(A)]	[dB(A)]
105	1	1	-	1	1	1
115	1	1	-	1	1	1
120	-	1	-	1	1	1
130	1	1	-	1	1	1
150	-	1	-	1	1	1
170	-	2	-	2	1	2
180	-	2	-	2	1	2
190	1	2	-	2	1	2
210	-	2	-	2	1	2

Operating conditions:

Outlet water temperature in/out 12°C/7°C – outdoor air temperature 35°C.

Testing point:

Average sound pressure levels calculated according to ISO 3744 at 10 mt distance from unit.

Measurement conditions:

Free field on reflecting surface (Q factor Q=2).

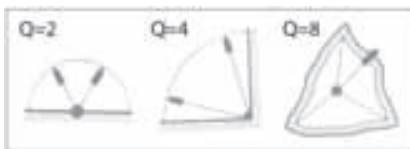

- For units installed in the presence of 2 reflecting surfaces (Q factor Q=4) 3 dB have to be added at values above mentioned.
- For units installed in the presence of 3 reflecting surfaces (Q factor Q=8) 6 dB have to be added at values above mentioned.
- For units installed at a certain height from the ground, the sound energy coming out from the bottom of the unit leads an increase of the noise pressure level of around 3 dB.

Sound emission values in octave bands are shown just as an indication and they are not to be considered as a commitment. Sound pressure values, according to ISO 3744 standards and in observance of EUROVENT certification program, are the only ones to be used for every calculation to make a prevision of the sound pressure level at the operating conditions. The sound pressure level data are not binding. For a more precise value please refer to the sound power level.

12. INSTALLATION SKETCH

CONNECTION SCHEME – STANDARD VERSION

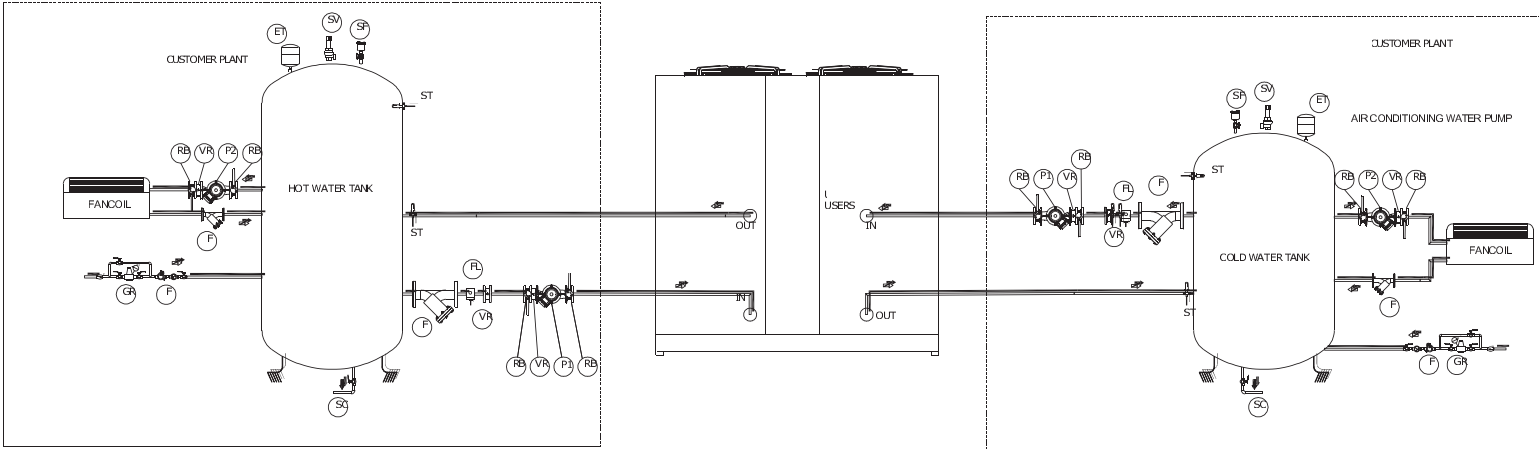

P1	Primary pump
P2	Secondary pump
ST	Temperature probe
FL	Flow switch
SC	Drainage
SF	Vent valve
ET	Expansion vessel
GR	Filling group
F	Steel mesh strainer
VR	Check valve
SV	Safety valve
RB	Interception valve



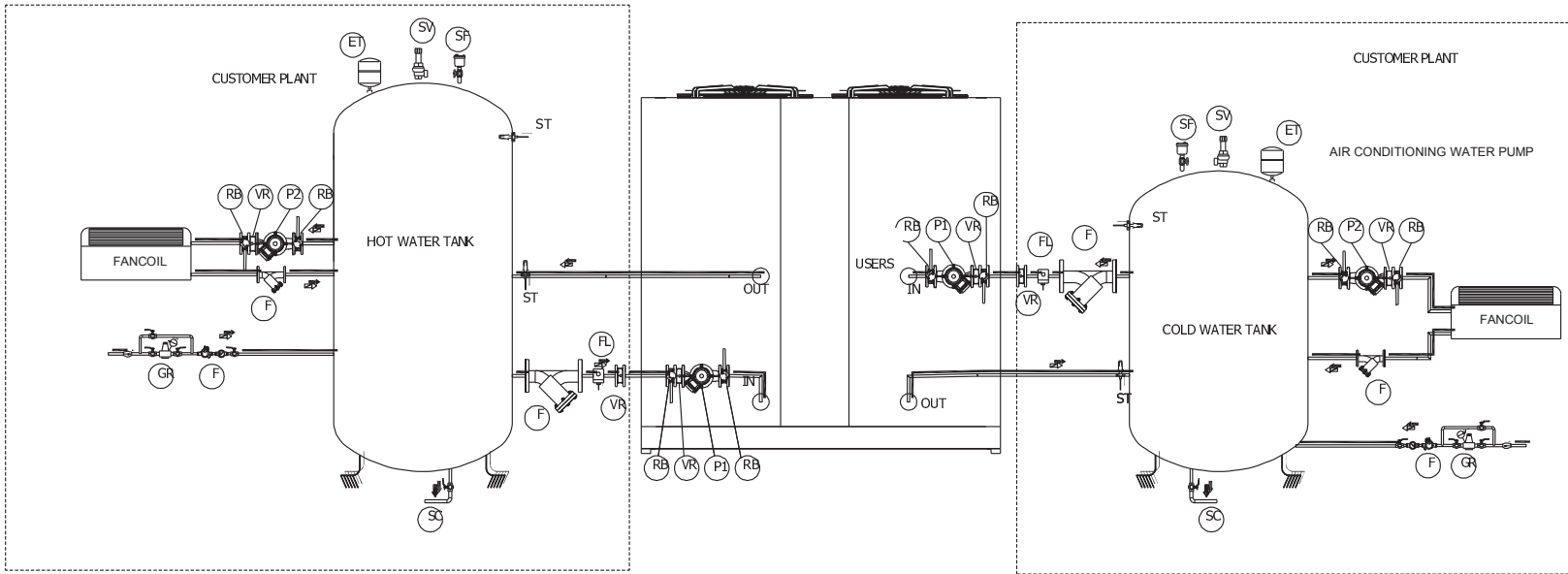

P1	Primary pump
P2	Secondary pump
ST	Temperature probe
FL	Flow switch
SC	Drainage
SF	Vent valve
ET	Expansion vessel
GR	Filling group
F	Steel mesh strainer
VR	Check valve
SV	Safety valve
RB	Interception valve

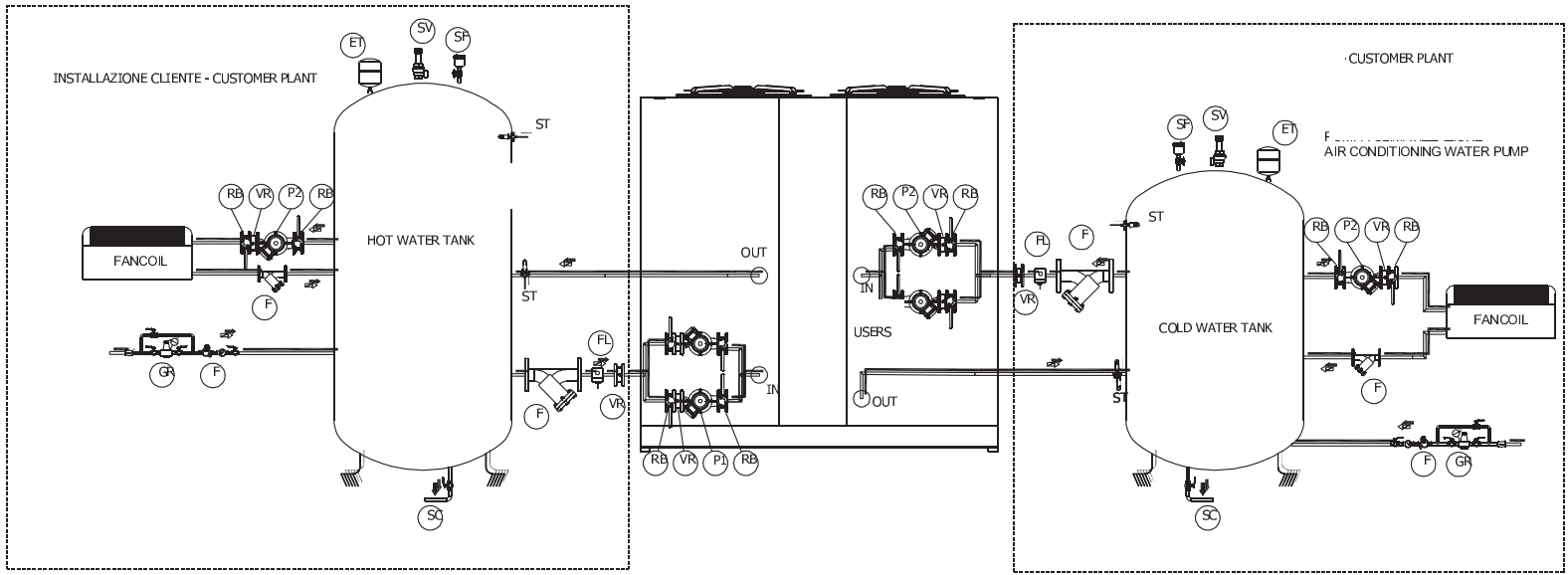

P1	Primary pump
P2	Secondary pump
ST	Temperature probe
FL	Flow switch
SC	Drainage
SF	Vent valve
ET	Expansion vessel
GR	Filling group
F	Steel mesh strainer
VR	Check valve
SV	Safety valve
RB	Interception valve

13. DIMENSIONAL DRAWINGS AND WEIGHTS.

RTMA 105 - 115

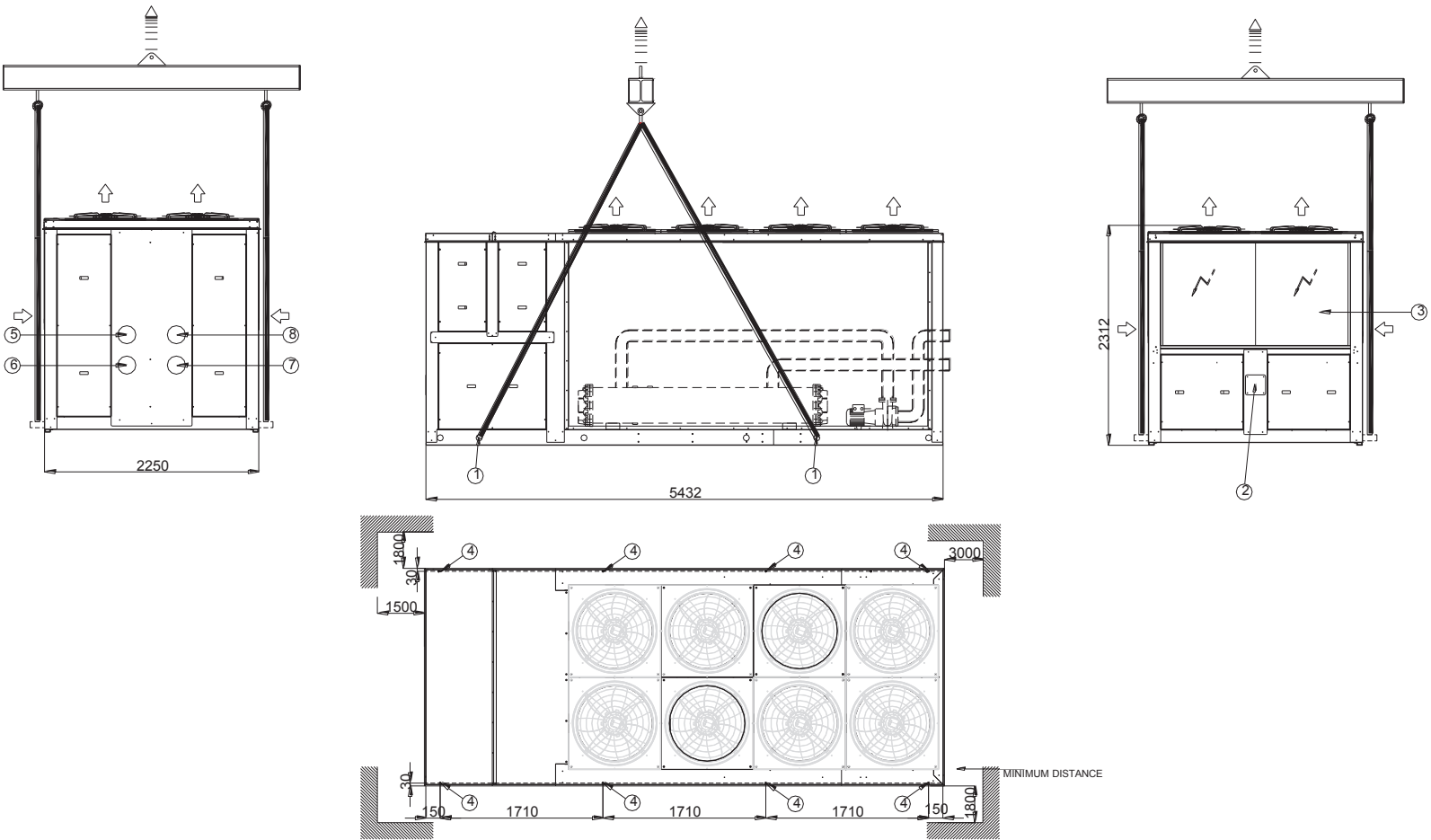

- 1 Ufting holes
- 2 Electronic power supply
- 3 Electric box
- 4 A/V mounting position
- 5 Chilled wáter inlet
- 6 Chilled wáter outlet
- 7 Hot wáter inlet
- 8 Hot wáter oultet

Operation weights		105	115
Basic Version	kg	5592	5799
Tubes diameter			
⑤ - ⑥	∅	5" VICTAULIC	5" VICTAULIC
⑦ - ⑧	∅	5" VICTAULIC	5" VICTAULIC
Operation weights for hydraulic version			
Single pump 150 kPa head pressure	kg	5903	6110
Double pump 150 kPa Head pressure	kg	6149	6356
Single pump 250 kPa head pressure	kg	5949	6156
Double pump 250 kPa Head pressure	kg	6241	6448
Single pump 450 kPa head pressure	kg	5991	6198
Double pump 450 kPa Head pressure	kg	6325	6532
Operation weights for acoustic version			
LN	kg	5592	5799
SL	kg	5872	6079
Single pump 150 kPa head pressure + SL	kg	6183	6390
Double pump 150 kPa Head pressure + SL	kg	6429	6636
Single pump 250 kPa head pressure + SL	kg	6229	6436
Double pump 250 kPa Head pressure + SL	kg	6521	6728
Single pump 450 kPa head pressure + SL	kg	6271	6478
Double pump 450 kPa Head pressure + SL	kg	6605	6812

MULTIPIPE CHILLER RTMA

RTMA 120 – 130

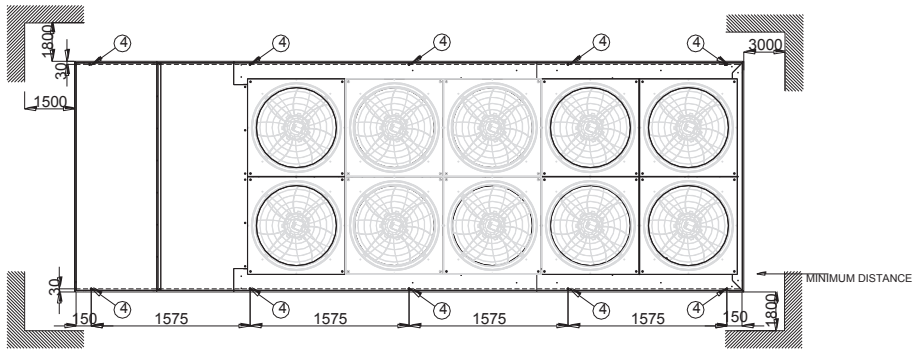
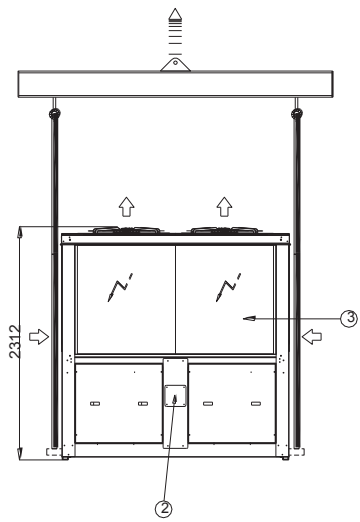
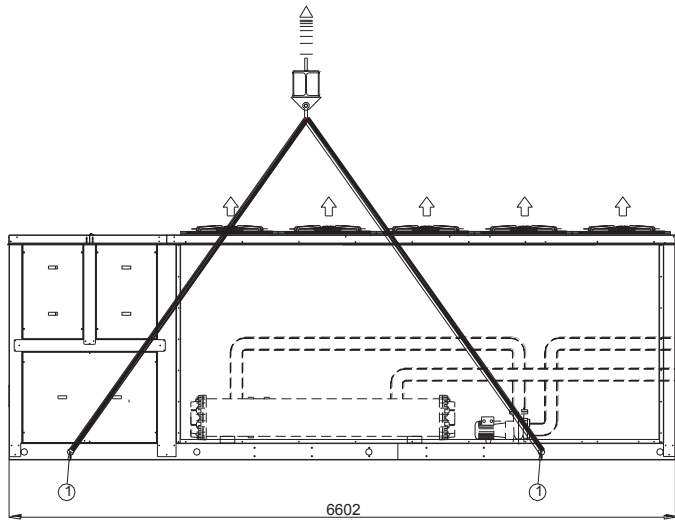
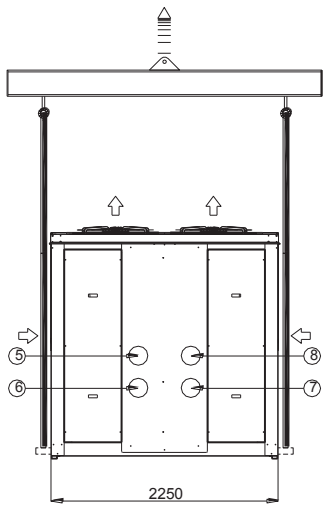

- 9 Lifting holes
- 10 Electronic power supply
- 11 Electric box
- 12 A/V mounting position
- 13 Chilled water inlet
- 14 Chilled water outlet
- 15 Hot water inlet
- 16 Hot water outlet

Operation weights		120	130
Basic Version	kg	6057	6121
Tubes diameter			
⑤ - ⑥	∅	5" VICTAULIC	5" VICTAULIC
⑦ - ⑧	∅	5" VICTAULIC	5" VICTAULIC
Operation weights for hydraulic version			
Single pump 150 kPa head pressure	kg	6368	6517
Double pump 150 kPa Head pressure	kg	6614	6831
Single pump 250 kPa head pressure	kg	6414	6529
Double pump 250 kPa Head pressure	kg	6706	6855
Single pump 450 kPa head pressure	kg	6456	6571
Double pump 450 kPa Head pressure	kg	6790	6939
Operation weights for acoustic version			
LN	kg	6057	6121
SL	kg	6387	6451
Single pump 150 kPa head pressure + SL	kg	6698	6847
Double pump 150 kPa Head pressure + SL	kg	6944	7161
Single pump 250 kPa head pressure + SL	kg	6744	6859
Double pump 250 kPa Head pressure + SL	kg	7036	7185
Single pump 450 kPa head pressure + SL	kg	6786	6901
Double pump 450 kPa Head pressure + SL	kg	7120	7269

MULTIPIPE CHILLER RTMA

RTMA 150 - 180

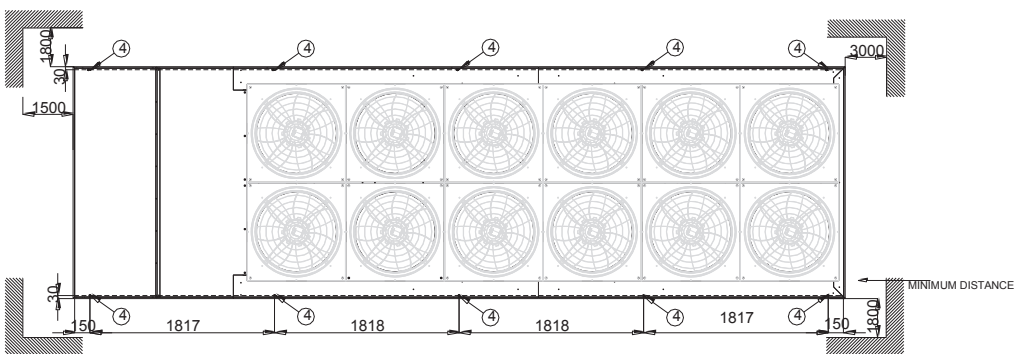
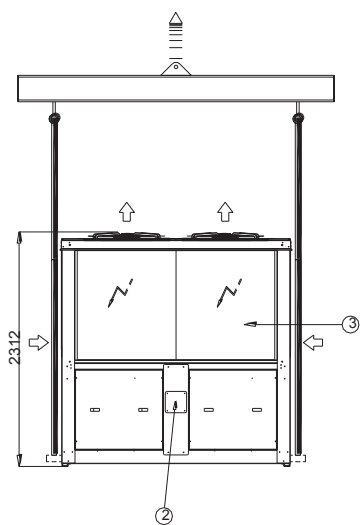
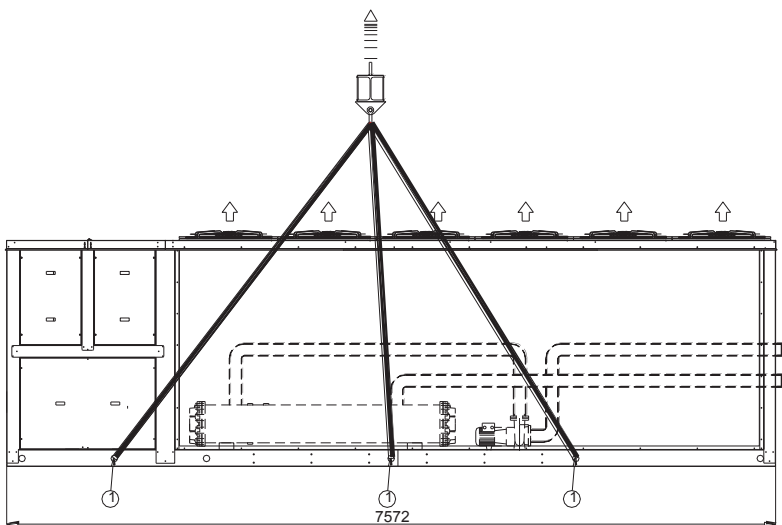
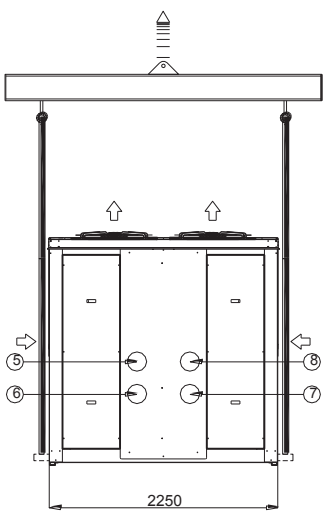

- 17 Ufting holes
- 18 Electronic power supply
- 19 Electric box
- 20 A/V mounting position
- 21 Chilled wáter inlet
- 22 Chilled wáter outlet
- 23 Hot wáter inlet
- 24 Hot wáter oultet

Operation weights		150	170	180
Basic Version	kg	6578	6925	6946
Tubes diameter				
⑤ - ⑥	∅	5" VICTAULIC	5" VICTAULIC	6" VICTAULIC
⑦ - ⑧	∅	5" VICTAULIC	6" VICTAULIC	6" VICTAULIC
Operation weights for hydric version				
Single pump 150 kPa head pressure	kg	7010	7411	7432
Double pump 150 kPa Head pressure	kg	7360	7797	7818
Single pump 250 kPa head pressure	kg	6986	7499	7520
Double pump 250 kPa Head pressure	kg	7312	7973	7994
Single pump 450 kPa head pressure	kg	7028	7769	7790
Double pump 450 kPa Head pressure	kg	7396	8513	8534
Operation weights for acoustic version				
LN	kg	6578	6925	6946
SL	kg	6948	7295	7316
Single pump 150 kPa head pressure + SL	kg	7380	7781	7802
Double pump 150 kPa Head pressure + SL	kg	7730	8167	8188
Single pump 250 kPa head pressure + SL	kg	7356	7869	7890
Double pump 250 kPa Head pressure + SL	kg	7682	8343	8364
Single pump 450 kPa head pressure + SL	kg	7398	8139	8160
Double pump 450 kPa Head pressure + SL	kg	7766	8883	8904

MULTIPIE CHILLER RTMA

RTMA 190 – 210

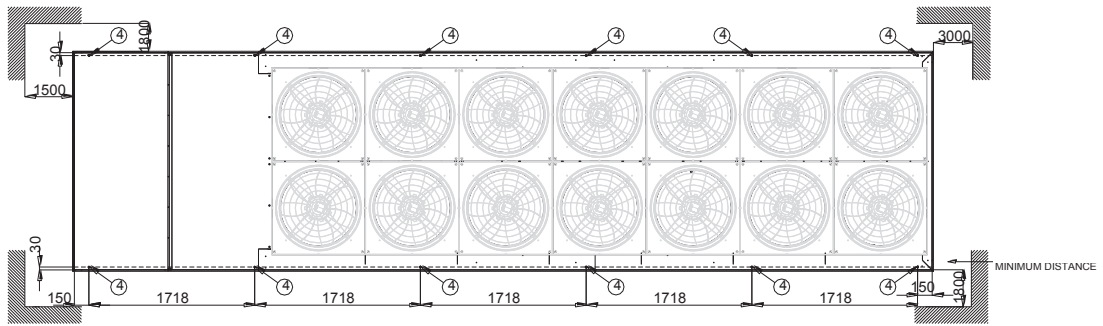
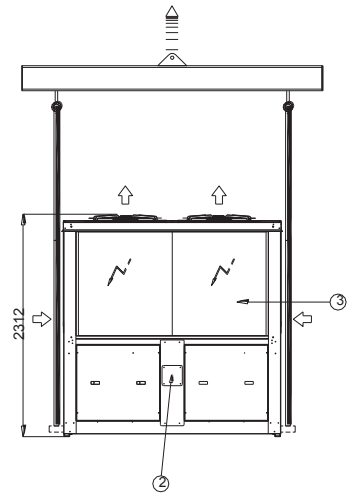
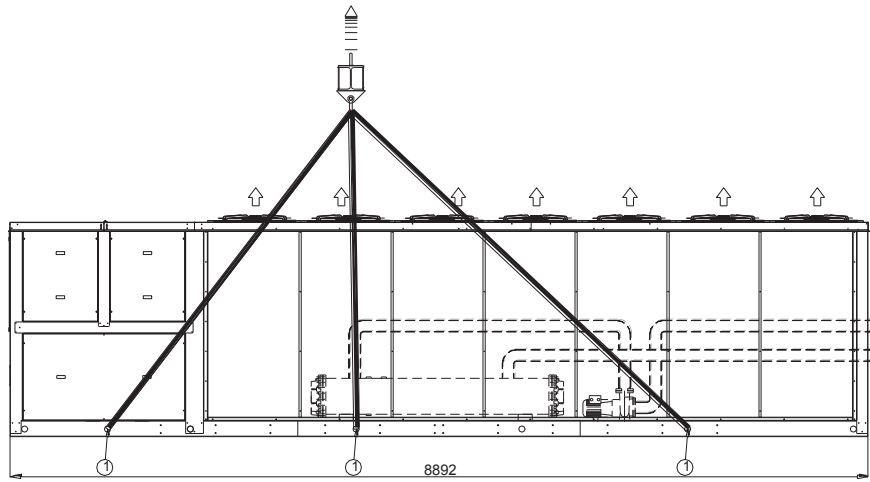
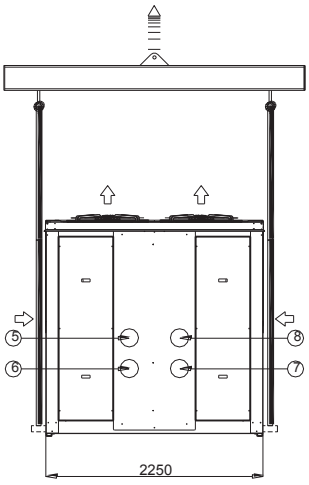

- 25 Ufting holes
- 26 Electronic power supply
- 27 Electric box
- 28 A/V mounting position
- 29 Chilled wáter inlet
- 30 Chilled wáter outlet
- 31 Hot wáter inlet
- 32 Hot wáter outlet

Operation weights		190	210
Basic Version	kg	7199	7794
Tubes diameter			
⑤ - ⑥	∅	6" VICTAULIC	6" VICTAULIC
⑦ - ⑧	∅	6" VICTAULIC	6" VICTAULIC
Operation weights for hydric version			
Single pump 150 kPa head pressure	kg	7733	8328
Double pump 150 kPa Head pressure	kg	8151	8746
Single pump 250 kPa head pressure	kg	7821	8416
Double pump 250 kPa Head pressure	kg	8327	8922
Single pump 450 kPa head pressure	kg	8091	8686
Double pump 450 kPa Head pressure	kg	8867	9462
Operation weights for acoustic version			
LN	kg	7199	7794
SL	kg	7619	8214
Single pump 150 kPa head pressure + SL	kg	8153	8748
Double pump 150 kPa Head pressure + SL	kg	8571	9166
Single pump 250 kPa head pressure + SL	kg	8241	8836
Double pump 250 kPa Head pressure + SL	kg	8747	9342
Single pump 450 kPa head pressure + SL	kg	8511	9106
Double pump 450 kPa Head pressure + SL	kg	9287	9882



Trane optimizes the performance of homes and buildings around the world. A business of Ingersoll Rand, the leader in creating and sustaining safe, comfortable and energy efficient environments, Trane offers a broad portfolio of advanced controls and HVAC systems, comprehensive building services, and parts. For more information, visit www.Trane.com.

Trane has a policy of continuous product and product data improvement and reserves the right to change design and specifications without notice.